

PLUS

For More Info 
Click Here --->

Copyboard **M-5**

User's Manual (CD-ROM Edition)



Thank you for your purchase of the PLUS Copyboard.
Please read this User's Manual (CD-ROM Edition) carefully before use
to take full advantage of the functions of this product. After you have
finished reading the manual, please keep it for future reference.

For More Info
Click Here ----> 

Trademarks

- Microsoft and Windows are registered trademarks or trademarks in the United States and other countries of the Microsoft Corporation.
- IBM and PC/AT are registered trademarks of International Business Machines Corporation of the United States.
- Adobe and Adobe Acrobat Reader are trademarks of Adobe Systems Incorporated.
- CompactFlash and CF are trademarks of SanDisk.

The trademarks of the various companies and the product trademarks, even when not written down, will be given due respect. Product names and company names appearing in this manual are registered trademarks or trademarks of the respective companies.

- (1) The contents of this manual may not be reprinted in part or whole without permission.
- (2) The contents of this manual are subject to change without notice.
- (3) Great care has been taken in the creation of this manual; however, should any questionable points, errors, or omissions be apparent, please contact us.
- (4) Notwithstanding Section (3), this company will not be responsible for any claims of loss or profit or other matters deemed to be the result of using this unit.
- (5) Manuals with incorrect collating or missing pages will be replaced.

Table of Contents

- IMPORTANT SAFETY INFORMATION ----- 4**
- Packaged Contents ----- 6**
- Names of Parts ----- 7**

- Installation and Assembly Instructions ----- 8**
- Read This Before Installing ----- 9**
 - Cautions on Installation ----- 9
 - Types of Installation ----- 9
- Installing on a Wall ----- 10**
- Installing on a Stand ----- 13**
 - Assembling the stand and mounting the copyboard horizontally ----- 13
 - Assembling the stand and mounting the copyboard vertically ----- 15
- Installing on a Partition-Panel ----- 17**
 - Assembly and installation ----- 17

- Operation Instructions ----- 19**
- Usage Guide ----- 19
- Names of Main Unit Controls and Connectors ----- 20**
 - Handling CF Memory Cards ----- 21
 - Scanning area ----- 21
- Operating the Copyboard ----- 22**
 - Connecting the AC power adapter and turning the power on and off ----- 22
 - Saving the Image on the Sheet ----- 23
 - Saving sheet images in the built-in memory ----- 23
 - Saving sheet images on a CF memory card ----- 24
 - Clearing the built-in Memory ----- 25
 - Scrolling the Sheet ----- 25
 - Vertical/Horizontal Position Setting ----- 25
- Storing Image Files on a Computer ----- 26**
 - Storing/Deleting Directly with USB Connections (from built-in memory or CF memory card) ----- 26
 - Using a PC Card Adapter or Memory Card Reader/Writer (USB type) ----- 30
 - Using a PC card adapter ----- 30
 - Using a memory card reader/writer (USB type) ----- 31
- Troubleshooting ----- 32**
- Specifications ----- 33**
- Quick Calibration ----- 34**

- Software Guide ----- 35**
- Before Using the Software ----- 36**
 - Software Contents and Overview ----- 36
 - Operating Environment ----- 36
- Windows 98SE Personal Computer and USB Connections ----- 37**
 - Driver Setup (Windows 98SE) ----- 37
 - Uninstalling the Driver (Windows 98SE) ----- 38
- Windows Me / 2000/ XP Personal Computer and USB Connections ----- 39**
- Disconnecting of the Copyboard ----- 40**
 - Windows 98SE ----- 40
 - Windows Me / 2000 / XP ----- 40
- M-5 Setup Utility ----- 41**
 - Installation ----- 41
 - Starting up ----- 41
- Electronic User's Manual ----- 42**
 - Acrobat Reader Installation ----- 42
 - Opening the M-5 User's Manual ----- 42
- PLUS Image Viewer ----- 43**
 - Installation ----- 43
 - Starting up ----- 43
- Deleting the Software ----- 44**

For More Info

Click Here --->



IMPORTANT SAFETY INFORMATION



WARNING

The unit's rear panel should never be opened by anyone other than a qualified serviceperson. There are many high voltage parts inside the unit, and touching them is dangerous. For replacement of the light source, internal inspections, adjustments, repairs or internal cleaning, please contact your store of purchase.



CAUTION

Continued use of the unit under abnormal conditions (when the unit is emitting smoke, unusual odors or sounds) could lead to fire or electric shocks.

Turn off the unit's power immediately, then unplug the AC power adapter from the power outlet.

Check that no more smoke, etc., is being emitted, then contact a sales outlet for repairs.

Repairing the unit yourself is dangerous. Never attempt to do so.

WARNING

This is a FCC class A product. In a home environment this product may cause radio interference in which case the user may be required to take adequate measures.



This symbol warns the user that uninsulated voltage within the unit may have sufficient magnitude to cause electric shock. Therefore, it is dangerous to make any kind of contact with any part inside of this unit.



This symbol alerts the user that important literature concerning the operation and maintenance of this unit has been included. Therefore, it should be read carefully in order to avoid any problems.



SAFETY PRECAUTIONS

Heeding the safety precautions below will lengthen the product's service life and prevent fires, electric shocks and injury. Read these safety precautions carefully and be sure to heed them.

Handling the AC power adapter

- Do not connect any AC adapter other than the dedicated one to the unit. Doing so could result in fire or other accidents.
- Do not use with voltages other than the voltage indicated. Doing so could result in fire or electric shock.
- Do not let the AC power adapter get wet. Doing so could result in fire or electric shock.
- Do not subject the AC power adapter to shocks. Doing so could result in fire or electric shock.

Handling the AC power adapter's cord and plug

- Damaging the power cord could lead to fire or electric shock.
 - * When installing, do not squeeze the power cord between the product and a wall, rack, etc.
 - * Do not modify or damage the power cord.
 - * Do not place heavy objects on the power cord or pull strongly on it.
 - * Do not place the power cord near heating appliances or otherwise heat it.
 - * When unplugging the power cord, always do so by pulling on the plug, not the cord.
- If the power cord should be damaged, ask your store of purchase to replace it.
- If there is dust or metal objects on or near the power plug's blades, unplug the power cord then wipe the blade area clean using a dry cloth. Continued use without cleaning the plug could lead to fire or electric shock.
- Do not plug in or unplug the power cord with wet hands. Doing so could lead to electric shock.
- When moving the unit, turn off the power and be sure to unplug the power cord from the AC outlet first. Moving the unit with the power cord plugged in could damage the cord, leading to fire or electric shock.
- Connect the power plug securely to the AC outlet, pressing the blades in to the hilt. Uncomplete plugging could cause heating or attract dust, leading to fire. In addition, touching the plug's blades could cause electric shock.

For More Info
Click Here --->



Do not use the included CD-ROM in a player designed for audio CDs.

- Never use the included CD-ROM in a player designed for audio CDs. Doing so could produce loud noises that could impair your hearing. These noises can also damage your speakers.

Installation

- When the copyboard is mounted on a stand, be sure to lock the casters.
- When mounting on a wall, be sure to check first that the wall surface is strong enough to support the total weight of the main unit and mount fittings over a long period of time (including during earthquakes). If the wall is not strong enough, reinforce it before mounting the unit.
- Getting water on or inside the unit etc., could lead to fire or electric shock. Be particularly careful when using the unit near a window when it is raining or snowing and when using it near the shore of the ocean and lakes.
- Do not set the unit in hot places exposed to direct sunlight or in places exposed to wind coming directly from an air conditioner. Do not set the unit in places exposed to soot or humidity (on kitchen counters, near humidifiers, etc.).

Preventing Tipping (when mounted on a stand)

To prevent tipping, heed the instructions below. Tipping could lead to personal injury or damage the unit.

- Place the unit on a flat floor.
- Lock the casters when using the unit. When moving it, be sure to unlock the casters to prevent tipping.
- Do not lean against the unit or apply excess force to the top of the unit.

Care and Cleaning

Cautions on Usage

- Take care that the unit does not get wet and that water does not get inside. Do not place objects containing chemicals, water or other liquids (vases, potted plants, glasses, cosmetics, etc.) on top of the unit. The liquid could spill and get inside the unit, leading to fire or electric shock.
- When lifting the unit to hang it on the stand, etc., the unit should be lifted by at least two persons to prevent it from tipping and causing personal injury.
- Do not move the sheet with paper or other objects attached to it. Doing so could cause damage.
- Do not wipe the unit or sheet with thinner, benzene, alcohol or other such products. Doing so could cause discoloration or damage the sheet.
- Only use markers designed exclusively for this product. Using other markers could damage the sheet. Also note that it may not be possible to erase the ink of other markers.
- When moving the unit mounting on the stand, be sure to unlock the casters, then support the unit from both sides and move it gently and carefully to avoid shocks.
- When not using for long periods of time, for safety be sure to unplug the AC power adapter from the power outlet.

Handling the CD-ROM

- Do not touch the surface on which nothing is printed (the surface on which the data is recorded). If this surface is dirty the data will not be read properly. Also, do not stick paper, stickers, etc., on the CD-ROM.
- Do not leave for long periods of time in places exposed to direct sunlight or near heating appliances, and do not drop or bend the CD-ROM. The disc may get warped, making it impossible to read the data.

Cleaning

- If the sheet is dirty, wipe it clean using a damp, thoroughly wrung out cloth. For tough dirt, apply some diluted neutral detergent to a cloth, wipe off the dirt, then wipe again to remove any detergent. Wait until the sheet is completely dry before using it.
- Do not wipe the copyboard or sheet with thinner, benzene, alcohol, etc. Doing so could cause discoloration or damage the sheet.
- Use a damp, thoroughly wrung out cloth to wipe any dust of markers on the marker tray or the frame.

For More Info

Click Here ---->



Packaged Contents

The contents included in the package are described below. Make sure that all items are included before starting.

Copyboard (main unit) ... 1



■ Accessories included with copyboard

- Set of markers ... 2 (black and red)
Use these special markers to draw or write on the sheet.

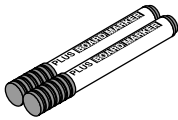

- Eraser ... 1
Use this to erase what you have drawn or written.

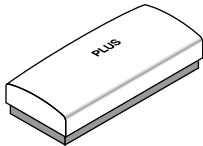

- AC power adapter (with 3 meter power cord) ... 1
This is the power adapter for supplying power to the copyboard.

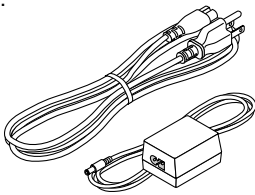

- USB cable (type B ↔ type A, 3 meters) ... 1
Use this cable to connect the copyboard with a computer.

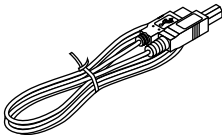

- Phillips screwdriver ... 1
Use this when setting up the Copyboard.



- Cosmetic seals ... 1 sheet for 11 pieces
To cover screw holes and screws, peel a cosmetic seal from the backing sheet and apply it.

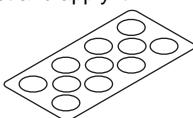

- Marker tray (1 set)
Put the markers and the eraser on this tray (when the copyboard is installed horizontally).
(Includes 2 side covers and 3 M4 x 8 screws)

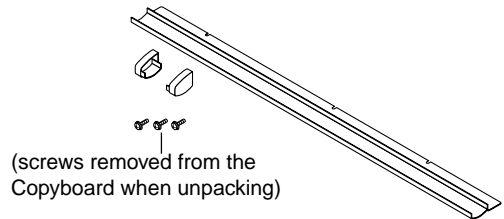

- Wall mount fittings (1 set)
Use these fittings to mount the copyboard to a wall.
(1 wall mount bar, 2 upper brackets, 2 lower brackets, 8 M4 x 12 bracket mounting screws)

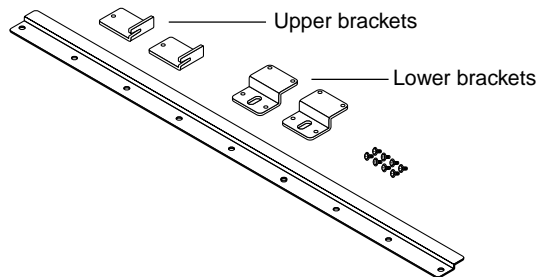

■ Documents

- Operating instructions (simplified version) ... 1
- Wall mount positioning sheet ... 1
- CD-ROM ... 1 (including operating instructions (in PDF format), Windows 98SE driver and PLUS Image Viewer)

For More Info

Click Here --->



Names of Parts

Front and top

For More Info
Click Here ---->

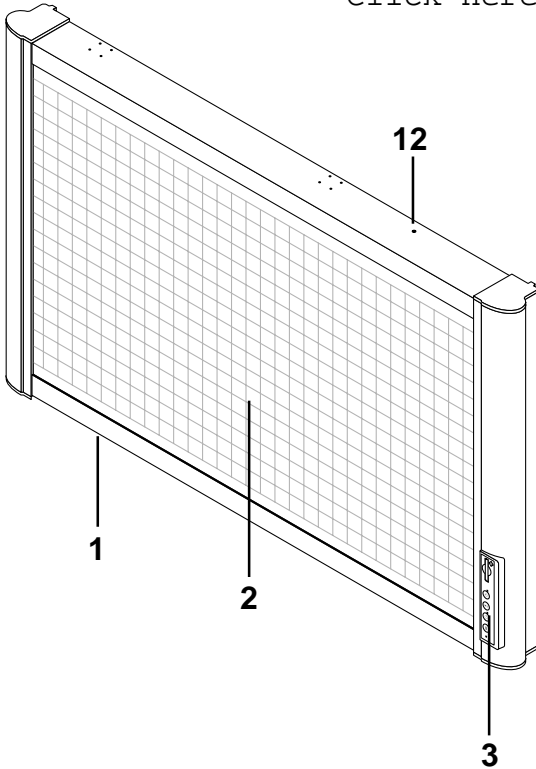

1. Copyboard
2. Sheet
3. Control panel (see page 20)
4. DC input jack (see page 20)
5. USB connector (type B) (see page 20)
6. Screw holes for mounting the marker tray
7. Screw holes for mounting the wall mount fittings (for upper brackets)
8. Screw holes for mounting the wall mount fittings (for brackets)
9. Screw holes for installing the stand horizontally (for upper brackets)
10. Screw holes for installing the stand horizontally (for lower brackets)
11. Screw holes for installing the stand vertically (for upper brackets)
12. Screw holes for installing the stand vertically (for lower brackets)

Back and bottom

This diagram shows the copyboard set with the front side facing down.

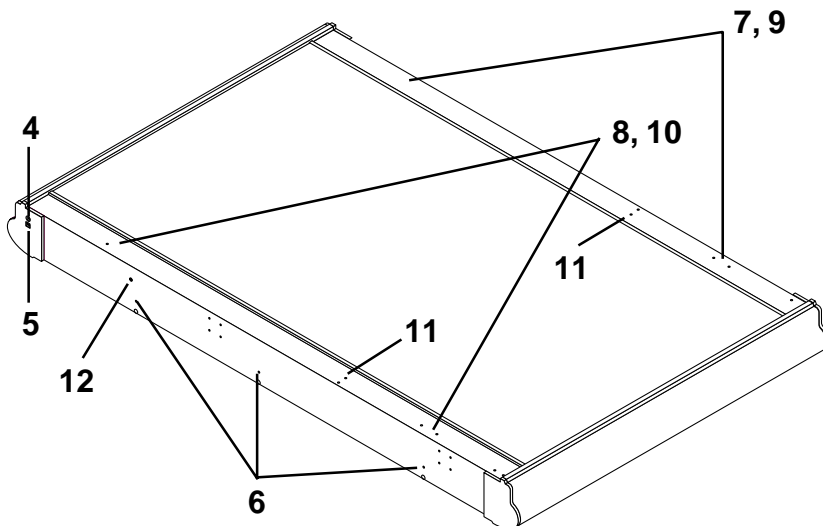

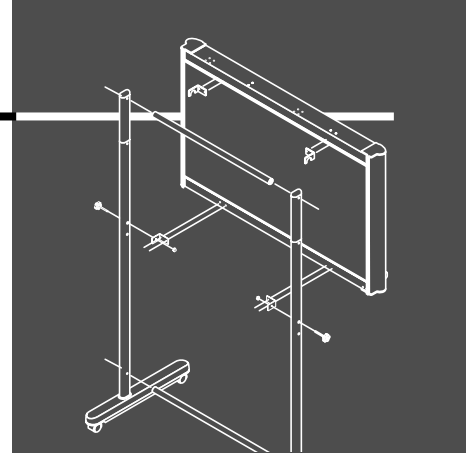

Installation and Assembly Instructions

To the Customer

Specialized techniques are required in the wall mounting of the Copyboard. Please do not attempt any installation work unless you have the techniques.

To the Dealer or Installation Tradesman

In the interest of the safety of the customer, please perform installation work paying due attention to the strength of the installation location to ensure that it can bear the load of the Copyboard and installation parts.

For More Info

Click Here --->



Read This Before Installing

Cautions on Installation

WARNINGS

- Be sure to install and assemble the copyboard as instructed in this manual. Improper installation or assembly could lead to injury.
- At least two people should hold the copyboard when installing and removing it.
- To prevent the copyboard from falling off the wall, install the copyboard on a sufficiently strong surface and in such a way that the weight of both the copyboard and the mounting hardware can be supported for an extended period of time, even in earthquakes. Improper installation could lead to the copyboard falling and causing injury.
- Use M6 screws or the equivalent to fix the copyboard to the wall. If any other screws are used, the copyboard could fall, causing injury.
- Install on a wall surface reinforced by sturdy studs.
- When installing on a concrete wall, use anchor nuts and anchor bolts.

Types of Installation

● On a wall (horizontal or vertical)

Horizontal Position:

Use the wall mount fittings included with the copyboard to mount the unit directly on the wall. The copyboard can be installed in the horizontal direction.

Vertical Position:

Use of the vertical wall mounting kit allows the Copyboard to be installed in the vertical orientation. (Vertical wall mounting kit: Model M-5-W, order code 44-563)

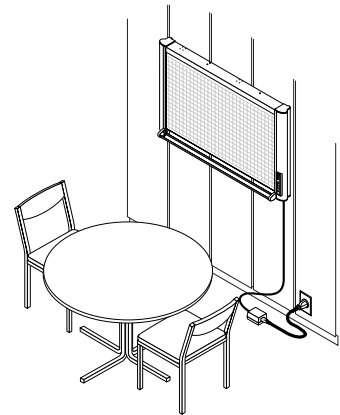

● On a stand (horizontal or vertical)

Mount the copyboard on an optional stand for mobility. The copyboard can be mounted in either the horizontal or vertical position. (Stand Kit : Model M-5-T, order code: 44-562)

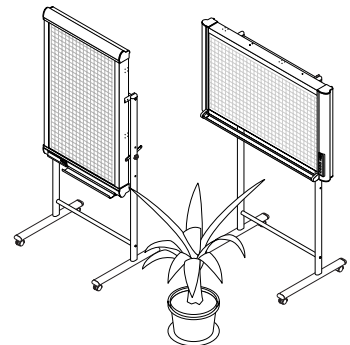

● On a partition-Panel

Use an optional partition mount kit to hang the copyboard onto a partition panel. (Partition hanger Kit : Model M-5-P, order code: 44-552)

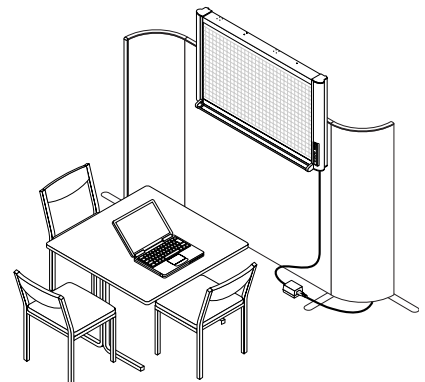

For More Info

Click Here --->



Installing on a Wall

Parts included in the copyboard package:

Wall mount bar (1 pc), upper brackets (2 pcs), Marker tray (1 pc, with 2 side covers) and M4 x 8 marker tray installation screws (3 pcs, screws removed when unpacking), lower brackets (2 pcs), M4 x 12 bracket mounting screws (8 pcs)

Parts not included in the copyboard package:

Bolts and nuts for fastening to wall (use commercially available parts – the types differ according to wall surface material). See page 11.

● Wall mounting procedure – flow



(1) Selecting the place of installation

- The wall mount bar should be mounted on columns, posts, or wall which is strong enough to support the weight of the copyboard.
- The diagram shows the wall mount bar's position of installation. The wall mount bar has 8 mm diameter screw holes at 100 mm intervals.
- Choose holes in such a way that the center of gravity will be at the middle. (Make sure there is no extreme imbalance.)
- The included "wall mount positioning sheet" can be used to easily mark the position of installation.

● For concrete walls

Mount commercially available M6 anchor bolts and anchor nuts to the position of installation. (See the following page.)

For More Info

Click Here --->



● For walls with a plywood or plaster board structure

Check that there are columns or studs at the position of installation.

Install using the wall mount bar's M6 wood screws, etc. (See the following page.)

Mount the lower brackets in the position on the diagram shown for the wood screws for when installing the copyboard.

Notice:

- For structures with no columns, use a separately sold stand.

An optional partition mount kit is also available for mounting the copyboard on a partition panel.

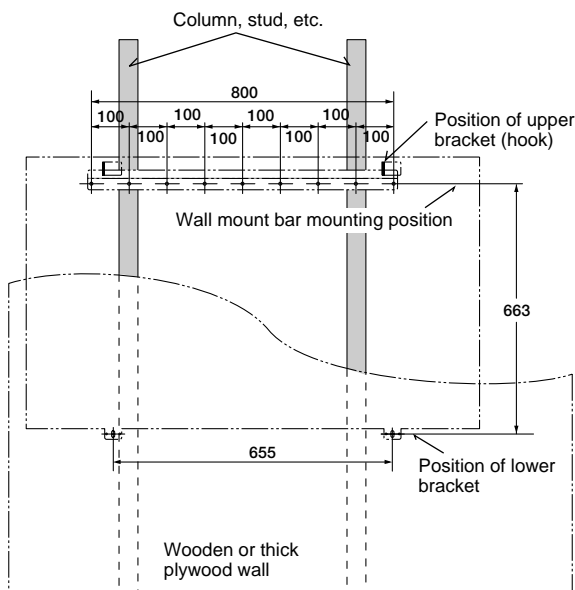
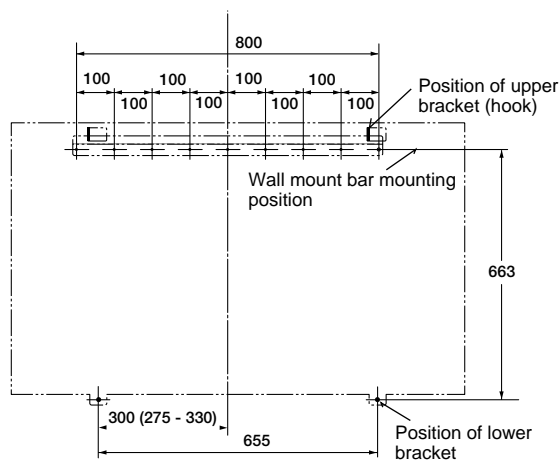

[Reference] Method of installation for different wall materials

Select the type of installation best suited for the wall material.

If the wall is not strong enough, mount the copyboard to columns or studs.

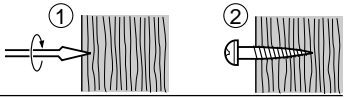
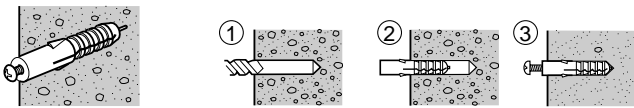
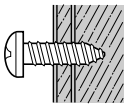
Material of wall	Method of installation
Wood	<p>Wood screws: ① Open holes using a drill, then ② mount the copyboard using wood screws.</p> 
Concrete	<p>U-plugs: ① Open the base hole in the wall using a drill, ② insert the U-plug, then ③ fasten the wall mount bar using screws.</p> 
Steel	<p>Cross recessed tapping screw (pan head): Check that there is reinforcement inside the steel wall, open holes with a drill of the proper diameter, then mount the wall mount bar using tapping screws.</p> 

(2) Fix the wall mount bar to the wall surface and posts.

- Fasten the screws in a minimum of 3 places.

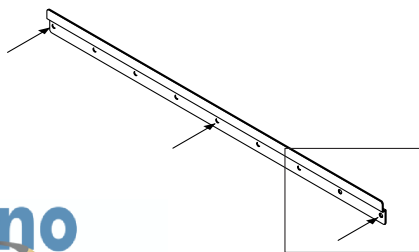

Mounting on the wall surface

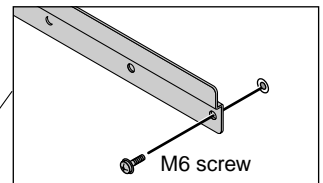

Mounting on a post

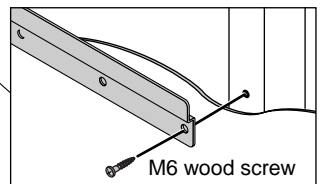

For More Info
 Click Here --->



(3) Attach the marker tray to the Copyboard.

- ① Insert the side covers into both ends of the marker tray.
 - Note that there are left and right type side covers.
- ② Temporarily fasten the three M4 x 8 screws into the Copyboard (leaving about 3 mm)
 - Use the supplied screwdriver.
- ③ Insert the marker tray over the 3 screws that have been temporarily fastened, and then tighten securely.
 - Please insert the marker tray as far as they will go.

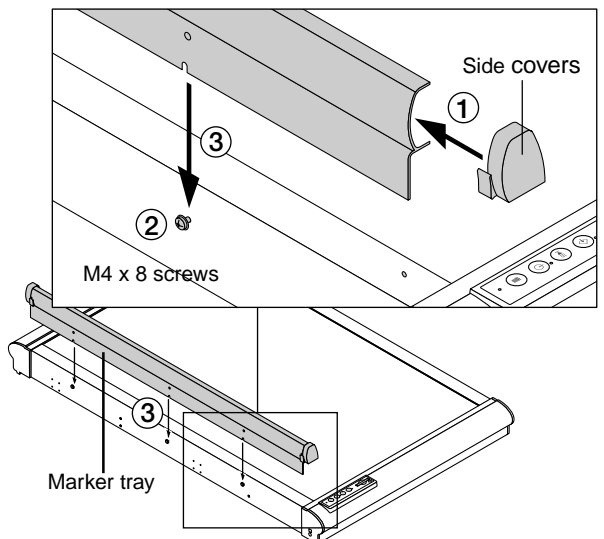

(4) Mount the 2 upper and 2 lower brackets included with the copyboard using M4 x 12 screws.

- Both of the left and right upper brackets are installed in the same orientation.

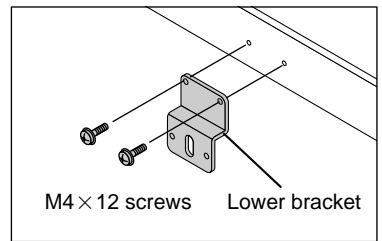
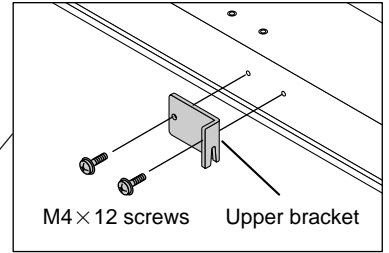
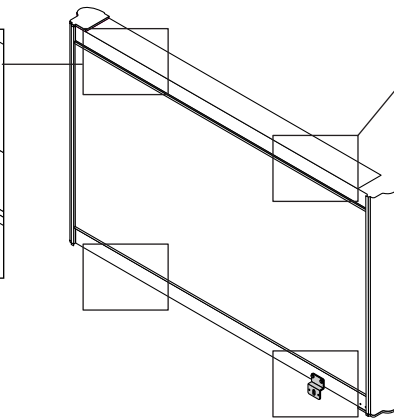
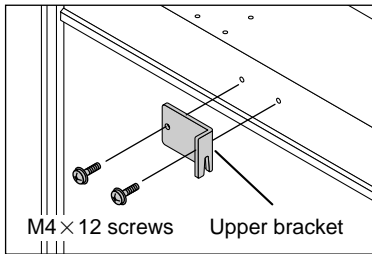

(5) Hang the copyboard to the wall mount bar and fasten the lower brackets.

- ① Catch the left and right upper brackets mounted on the copyboard onto the wall mount bar.

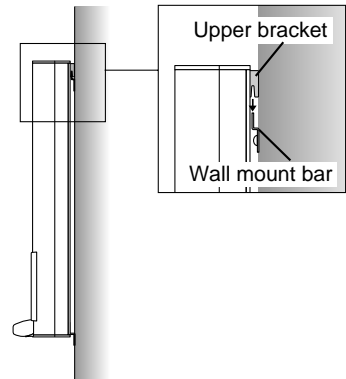

For More Info

Click Here --->



- ② Fix the left and right lower brackets to the wall surface. (The way in which the brackets are fixed to the wall depends on the type of installation to the wall.)

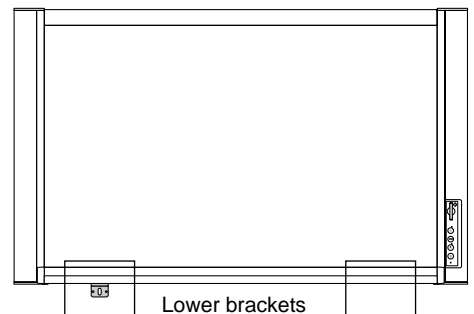

! CAUTION

- The upper brackets are not fastened. Do not let the copyboard slide too much when fixing the lower brackets. Doing so may cause the copyboard to come off the wall mount bar and fall, resulting in injury.
- At least two people should hold the copyboard to prevent it from dropping or tipping over, resulting in unexpected injury.

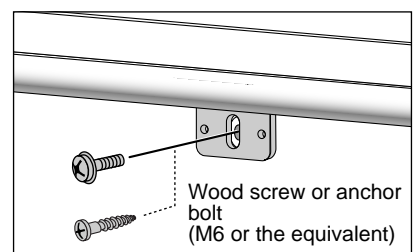

Installing on a Stand

The optional stand kit for both vertical and horizontal installation (Model M-5-T, order code 44-562) is required to install the copyboard on a stand.

Assembling the stand and mounting the copyboard horizontally

Parts included in the copyboard package: Marker tray (1 pc), side covers (2 pcs), M4 x 8 marker tray installation screws (3 pcs, screws removed when unpacking), 8 copyboard mount screws (M4 x 12)

List of parts included in the stand kit (parts used for horizontal installation)

Feet (with casters) : 2, Frames : 2, Foot washers : 2, Foot fixing screws (M8 x 50) : 4, Spring washers : 4, Extension frames : 2, Caps : 6, Fixing knobs (with hexagon cap nuts) : 2, Crossbars : 2, Hexagonal socket head screws : 4, Flat washers : 4, Upper brackets (left and right) : 2, Lower brackets : 2, Hexagonal wrench (M8) : 1, Hexagonal wrench (M5) : 1

● Assembly and installation flow

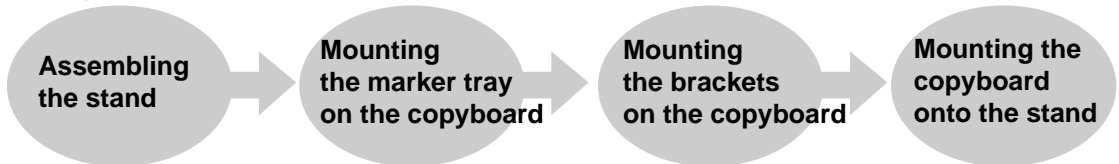

(1) Assemble the T-shaped legs (two).

- ① Mount the foot using washers, spring washers and M8 x 50 hexagonal socket head screws.
- ② Make sure of the orientation of the extension frame and the frame end looking at the marks, then insert all the way. (Note that it will no longer be possible to remove the extension frame when the mark surface has been inserted in the opposite orientation.)

Notice:

- Mounting the extension frame makes for a height of 1700 mm off the floor (compared to 1465 mm without the extension frame). Use this to adjust the height.
- For the assembly procedure when not mounting the extension frames, see step (1) under "Assembling the stand and mounting the copyboard vertically".

- ③ Fit the caps on the top of the frame and feet.

(2) Mount the two crossbars onto the T-shaped legs assembled in (1) above.

Mount them using the M5 hexagonal socket head screws and flat washers. Temporarily fasten the screws using the included M5 hexagonal wrench, then fasten them securely once both the upper and lower crossbars have been mounted.

* Assemble in a flat place.

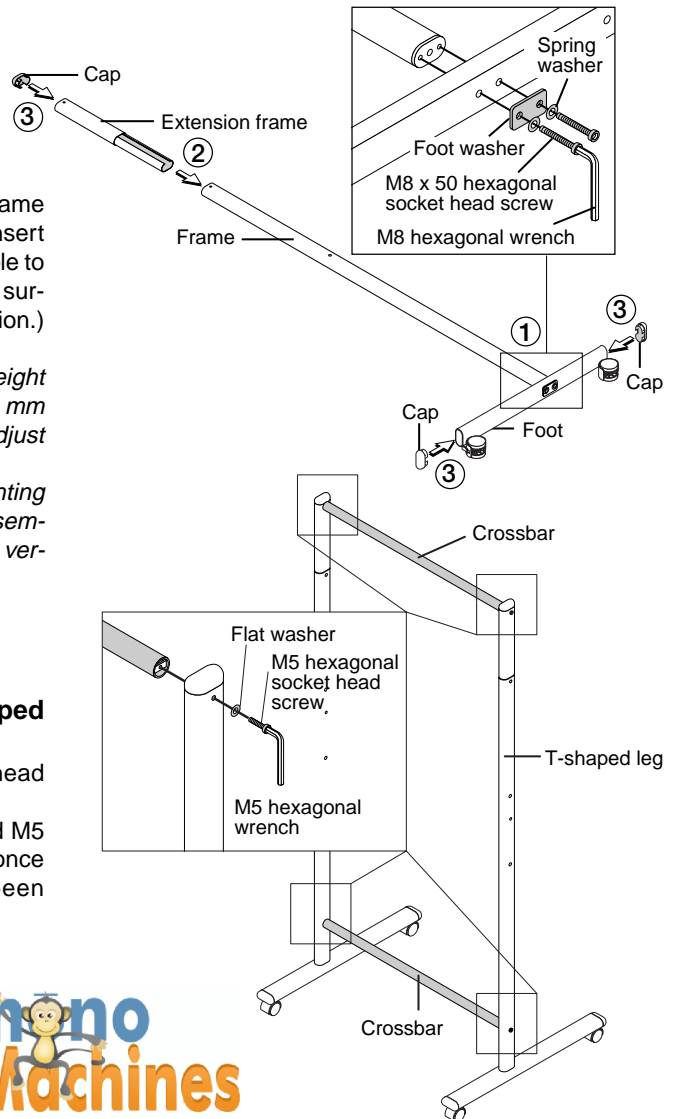

For More Info
Click Here ---->



(3) Attach the marker tray to the Copyboard.

- ① Insert the side covers into both ends of the marker tray.
 - Note that there are left and right type side covers.
- ② Temporarily fasten the three M4 x 8 screws into the Copyboard (leaving about 3 mm)
 - Use the supplied screwdriver.
- ③ Insert the marker tray over the 3 screws that have been temporarily fastened, and then tighten securely.
 - Please insert the marker tray as far as they will go.

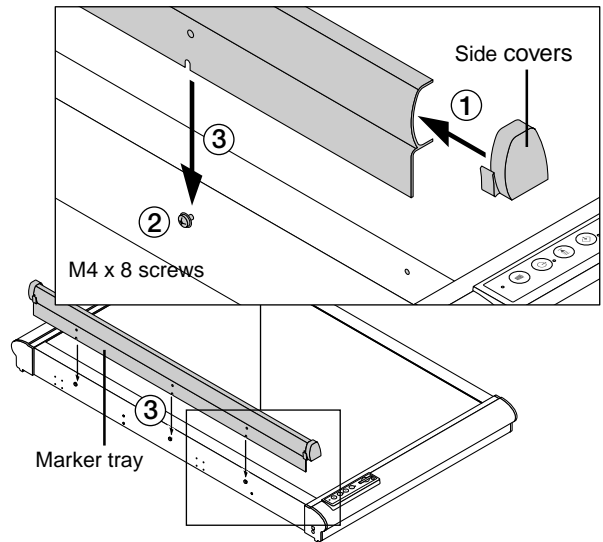

(4) Mount the upper and lower brackets using M4 x 12 screws.

- The left and right upper brackets are different. Be sure to mount them on the proper side.
- Both the lower brackets have the same form, but mount them in the opposite directions so that each is facing outwards.

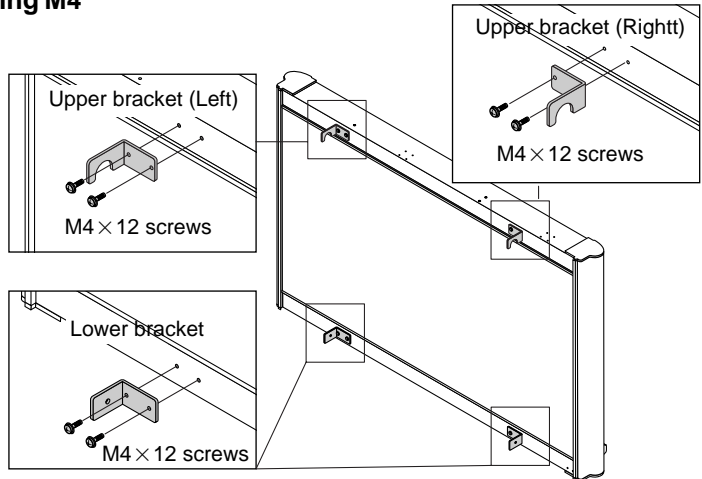

(5) Hook the left and right upper brackets of the Copyboard onto the upper crossbar and fasten the lower brackets using the fixing knobs and hexagon cap nuts.

For More Info
Click Here --->



⚠ CAUTION

- Lock the casters so that the stand does not move.
- When mounting and adjusting the height, at least two people should hold the copyboard to prevent it from dropping or tipping over, resulting in unexpected injury.

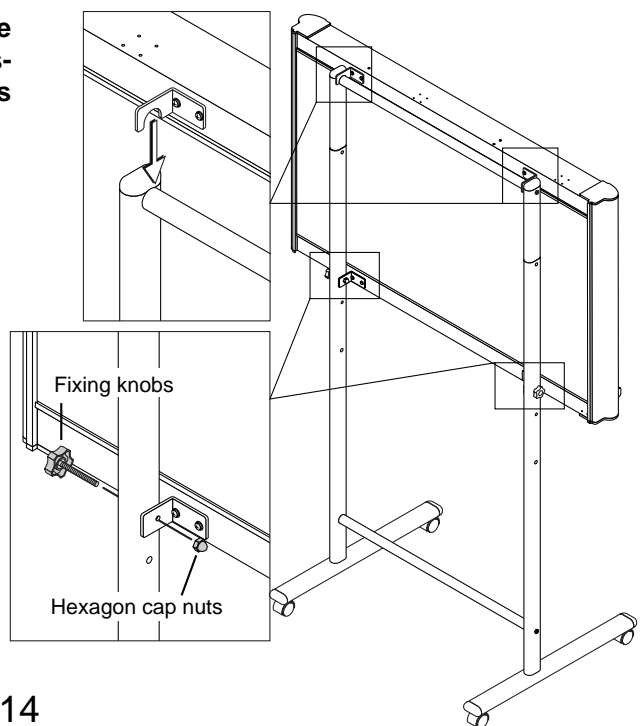

Assembling the stand and mounting the copyboard vertically

Parts included in the copyboard package: 6 copyboard mount screws (M4 x 12)

List of parts included in the stand kit (parts used for vertical installation)

Feet (with casters) : 2, Frames : 2, Foot washers : 2, Foot fixing screws (M8 x 50) : 4,

Spring washers : 4, Caps : 6, Fixing knobs (with hexagon cap nuts) : 2, Crossbars : 2,

Hexagonal socket head screws : 4, Flat washers : 4, Upper brackets (left and right) : 2, Lower brackets : 2,

Hexagonal wrench (M8) : 1, Hexagonal wrench (M5) : 1, Short marker tray:1, Side covers: 2

M3 decorative screws : 2

● Assembly and installation flow

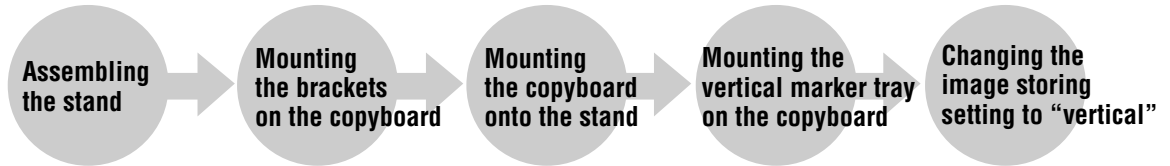

(1) Assemble the T-shaped legs (two).

① Mount the foot using two M8 x 50 screws (+ spring washers).

② Fit the caps on the top of the frame and feet.

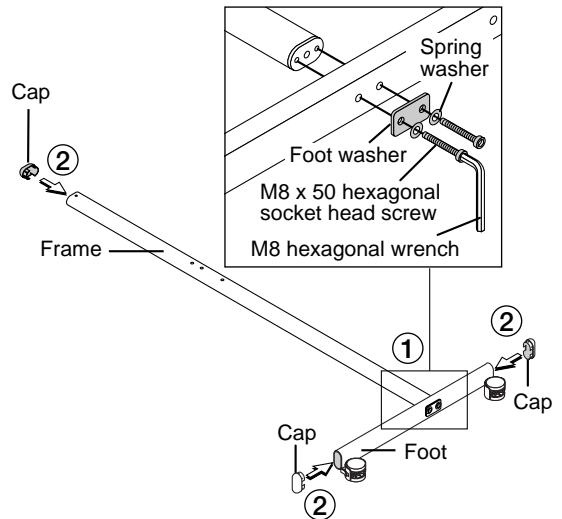

For More Info

Click Here --->



(2) Mount the two crossbars onto the T-shaped legs assembled in (1) above.

Mount them using the hexagonal socket head screws and flat washers.

Temporarily fasten the screws using the included hexagonal wrench, then fasten them securely once both the upper and lower crossbars have been mounted.

* Assemble in a flat place.

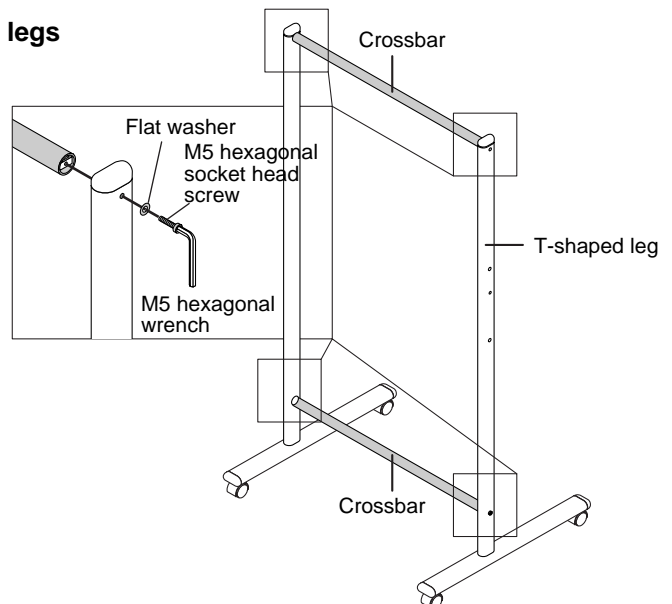

(3) Mount the upper and lower brackets using M4 x 12 screws.

- The left and right upper brackets are different. Be sure to mount them on the proper side.

For More Info

Click Here ---->

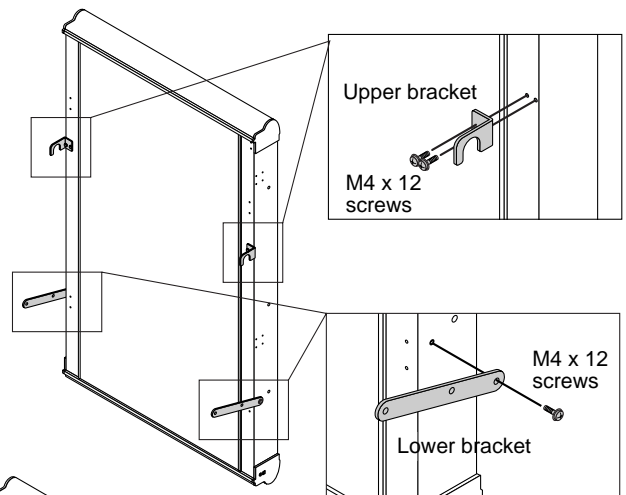

(4) Hook the left and right upper brackets of the Copyboard onto the upper crossbar and fasten the lower brackets using the fixing knobs and hexagon cap nuts.

There are two screw holes for adjusting the angle (upright or 10 degrees) on each lower bracket. Use the desired screw holes.

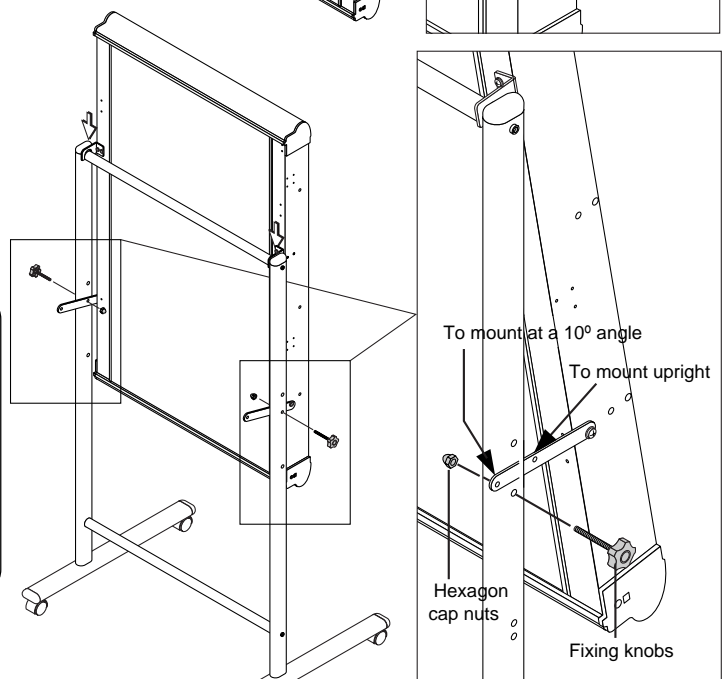

CAUTION

- Lock the casters so that the stand does not move.
- When mounting and adjusting the height, at least two people should hold the copyboard to prevent it from dropping or tipping over, resulting in unexpected injury.

(5) Mount the short marker tray.

- 1 Peel off the two cosmetic seals to expose the screw parts.
- 2 Insert the side covers into both ends of the short marker tray.
 - Note that there are left and right type side covers.
- 3 Temporarily fasten the two M3 decorative screws to the Copyboard (leaving about 3 mm).
- 4 Insert the marker tray over the two screws that have been temporarily fastened, and tighten securely.
 - Please insert the short marker tray as far as they will go.

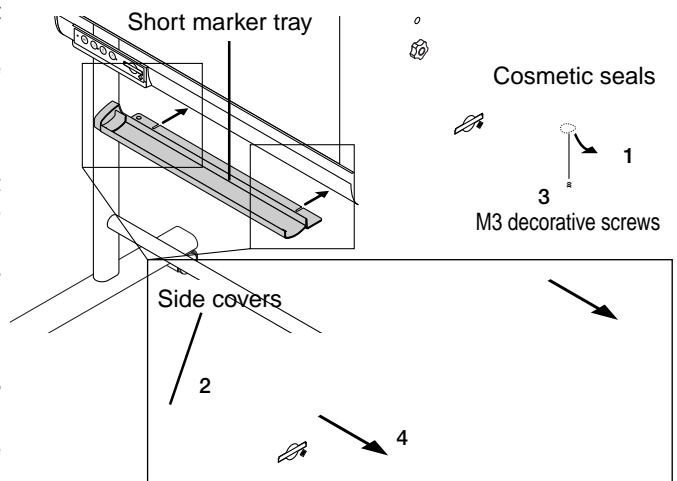

(6) Change the direction of image data ("POSITION") to "vertical".

This sets the direction in which the images are stored. (See page 25.)

Installing on a Partition-Panel

The optional partition hanger kit (Model M-5-P, order code 44-552) is required to install the copyboard on a partition-panel.

Assembly and installation

Parts included in the copyboard package : Marker tray (1 pc), side covers (2 pcs), M4 x 8 marker tray installation screws (3 pcs, screws removed when unpacking)

List of parts included in the partition hanger kit

Partition hangers : 2, Hanger brackets : 2, Hooks : 2, M4 x 12 screws : 8 (a), M4 x 8 flat head screws : 4 (b), M4 x 6 screws : 4 (c)

● Assembly and installation flow

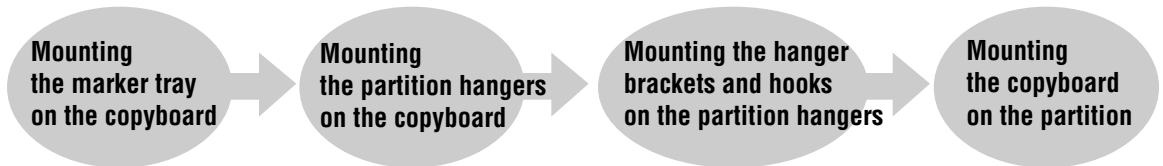

(1) Attach the marker tray to the Copyboard.

- ① Insert the side covers into both ends of the marker tray.
 - Note that there are left and right type side covers.
- ② Temporarily fasten the three M4 x 8 screws into the Copyboard (leaving about 3 mm)
 - Use the supplied screwdriver.
- ③ Insert the marker tray over the 3 screws that have been temporarily fastened, and then tighten securely.
 - Please insert the marker tray as far as they will go.

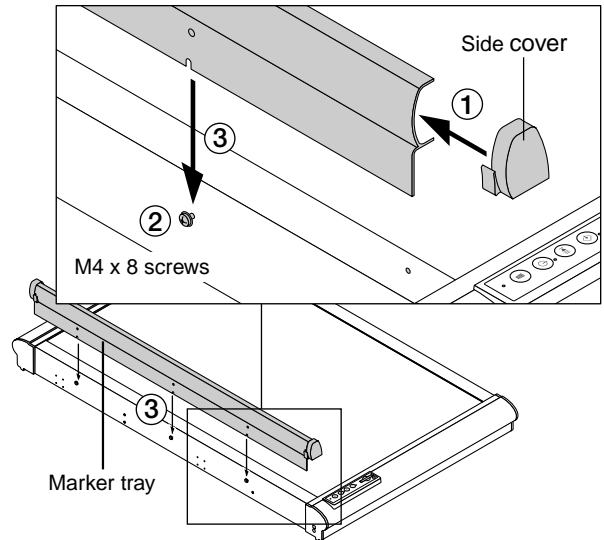

(2) Mount the partition hangers onto the copyboard (fasten at 4 spots).

Use the (a) M4 x 12 screws (2 each).

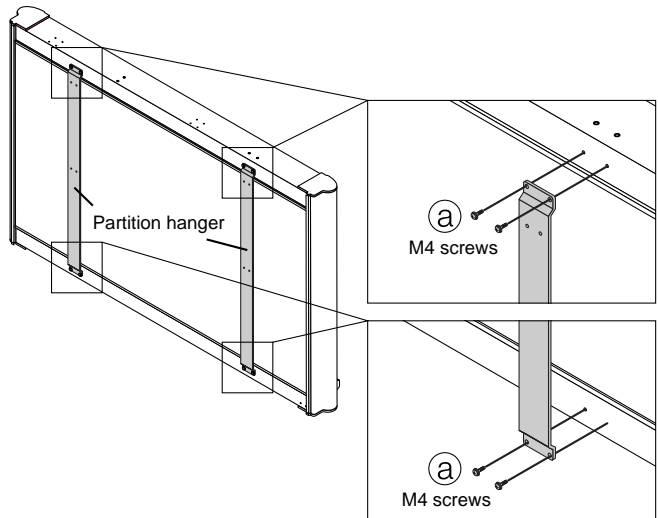

For More Info
Click Here --->



(3) Mount the hanger brackets to the screw holes at the middle of the partition hangers (left and right).

- Use the (b) M4 flat head screws.
- The partition hangers have screw holes for mounting hanger brackets at both the top and middle. Use the top holes when mounting the copyboard on a tall panel.

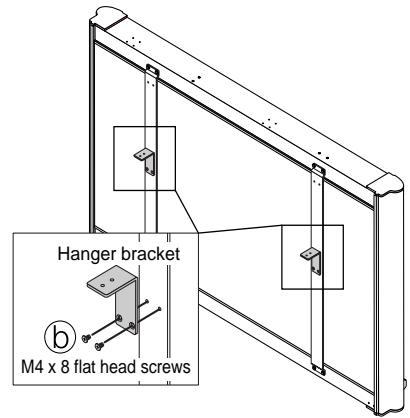
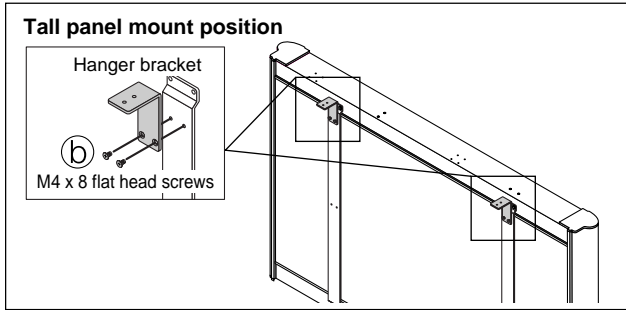

(4) Mount the hooks (2) to the tops of the hanger brackets using (c) M4 x 6 screws (2 each).

- First fasten the hooks loosely to the maximum width of 60 mm to make it easier to hang the copyboard on the panel.
- The hanger brackets can be used for panels of 50 to 60 mm thickness.

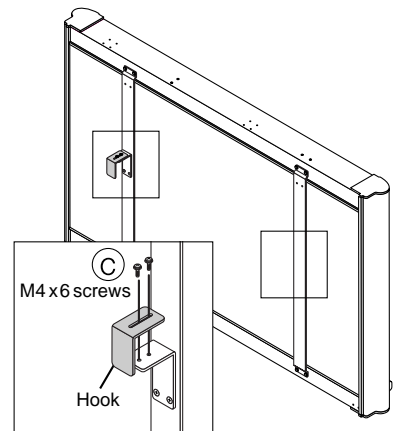

For More Info

Click Here --->



(5) Mount the copyboard on the partition panel.

Catch the hooks onto partition panel.
Take the panel in the hooks so as to fit snugly to the thickness then fully tighten the hooks' screws.

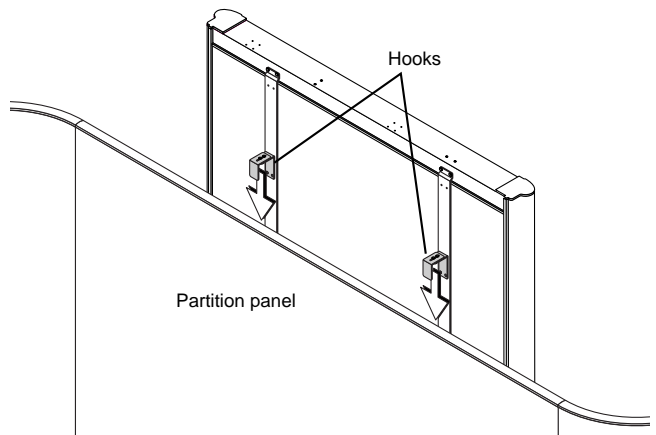

! WARNING

- The copyboard sits freely on the partition, it is not fixed to it. Do not push the copyboard upwards or otherwise lift it. Doing so may cause it to come off the partition and drop.

! CAUTION

- If the partition panel is not stable, take the necessary measures to keep it from tipping over, by for example fastening its feet or struts to the floor, etc.

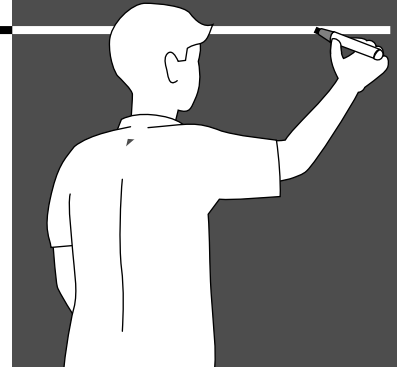

Operation Instructions

This manual contains information pertaining to the copyboard.

For instructions on the included software, please refer to the software's help file.

■ Usage Guide

● Saving and Transferring images

If you need to save a copy of what you have written on the copyboard, you can store it in the built-in memory. (page 23)

The image data stored in the built-in memory or on a CF memory card can be transferred directly to a computer using USB connections. (page 26)

● Storing images on CF memory cards

In addition to the built-in memory, large amounts of data can be stored on CF memory cards or on computers. (page 24, 26)

The data stored on CF memory cards can be stored on a computer either by using a commercially available PC card adapter or CF card reader/writer, or directly with USB connections when the CF memory card is inserted into the copyboard's card slot. (page 26)

● Editing and printing images

Files stored in the built-in memory or on a computer can be edited, deleted or printed using the imaging software of Windows, the "PLUS Image Viewer" utility contained in the CD-ROM or other image editing programs you may have. (page 43)

● Applications of copyboard data

The data can be sent as e-mail attachments.

It can also be converted into data formats that can be used to create or edit documents using the "PLUS Image Viewer" contained in the CD-ROM or other image software you may have. (page 43)

For More Info

Click Here --->



Names of Main Unit Controls and Connectors

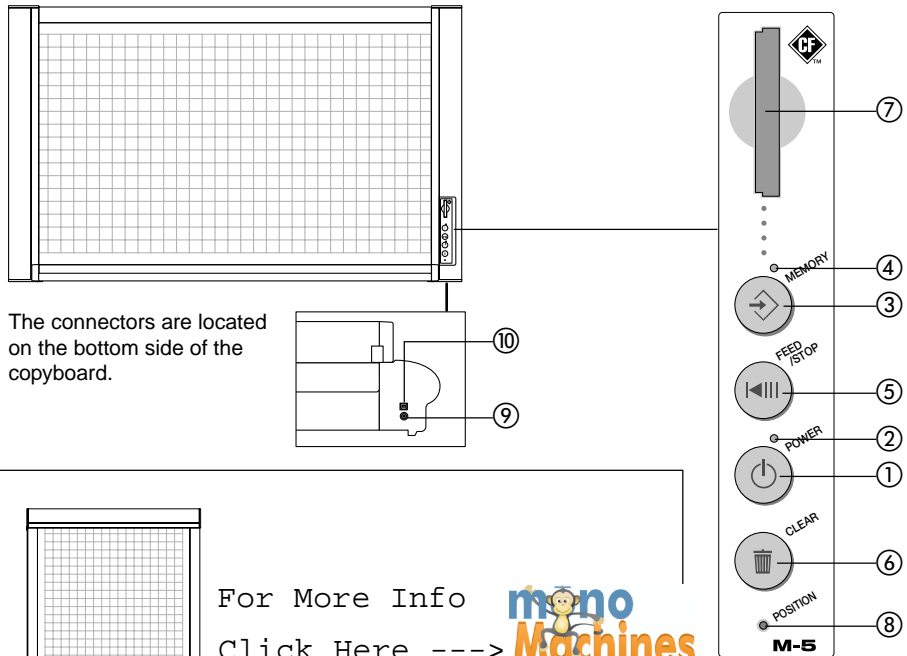

The connectors are located on the bottom side of the copyboard.

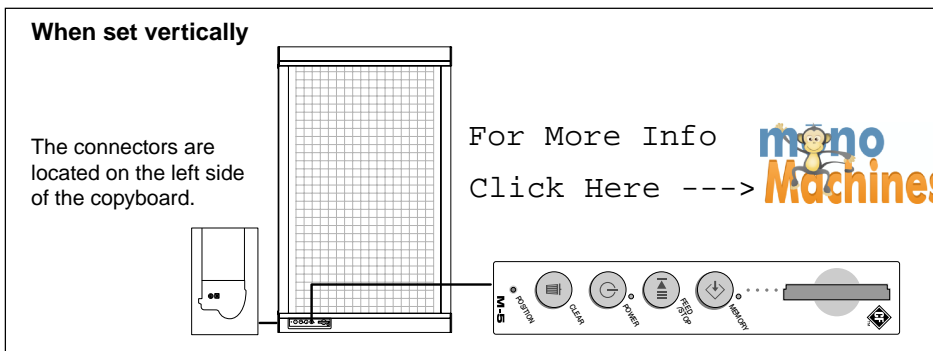

When set vertically

The connectors are located on the left side of the copyboard.





For More Info  Click Here --->

- ① **POWER button**
Use this to turn the power on and off.
- ② **POWER indicator (Green)**
This lights when the power is turned on and turns off when the power is turned off. The indicator flashes to indicate errors or the operating status.
- ③ **MEMORY button**
Use this to save drawings, words, etc., you have drawn or written on the sheet surface into the memory.
- ④ **MEMORY indicator (Amber)**
This blinks when the data is being stored in the memory. Depending on the speed at which it is blinking, it may also indicate an error.
- ⑤ **FEED/STOP button**
Use this to automatically feed 1 sheet or to stop feeding.
- ⑥ **CLEAR button**
Use this to clear all the image data in the built-in memory (when pressed for at least 3 seconds).
- ⑦ **Card slot**
This card slot is exclusively for CF memory cards.
- ⑧ **POSITION button**
(pin hole – button is located at bottom of hole)
Use this to switch the image to be stored in the memory between the vertical and horizontal mode.
- ⑨ **DC power jack**
Connect the DC side of the AC power adapter here. (Never connect anything other than the dedicated AC adapter.)
- ⑩ **USB connector (type B)**
Connect this to a computer's USB port (type A).

Notice:

Indicator blinking frequencies and terms used in this manual

The blinking of the indicators is used to indicate both the copyboard's operating status and errors. In this manual the frequencies are expressed as shown below.

Terms in manual	Blinking frequency	Diagram of flashing
Blinking slowly	Lit 0.5 seconds, off 0.5 seconds	
Blinking quickly	Lit 0.25 seconds, off 0.25 seconds	
Blinking intermittently	Lit 0.25 seconds, off 0.25 seconds, lit 0.25 seconds, off 1.25 seconds	
Error blinking	The (amber) Memory indicator and the (green) Power indicator blink alternately at high rate.	

Handling CF Memory Cards

- We recommend backing up data stored in the built-in memory or on CF memory cards onto other recording media periodically to secure the data in case of damage or loss.
- Note that PLUS will accept no responsibility whatsoever for loss or damage of stored data.
- Please use a memory card having specifications that conform with the CompactFlash standard (which supports an operating voltage of 3.3 V / 5 V).
- * CompactFlash memory cards are referred to as "CF memory cards" in this manual.

Inserting CF memory cards

● When using in the horizontal position

With the surface of the CF memory card facing the left, insert the card vertically, pressing it slowly to the end.

● When using in the vertical position

With the surface of the CF memory card facing the up, insert the card horizontally, pressing it slowly to the end.

Note:

- Insert the CF memory card slowly.
- The slot is designed so the card cannot be inserted in the wrong direction. Trying to force it will result in damage.

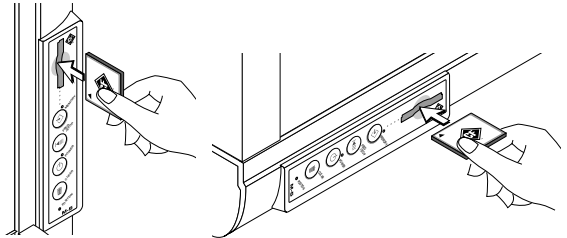

Removing the CF memory card

Check that the MEMORY indicator has stopped blinking and turned off, then pull the CF memory card out.

Note:

- Do not pull off the CF memory card or disconnect the AC power adapter's cable while data is being stored in the memory (when the MEMORY indicator is blinking). Doing so will damage the data.
- The CF memory card can be replaced while the MEMORY indicator is blinking intermittently, indicating there is not enough free memory left.

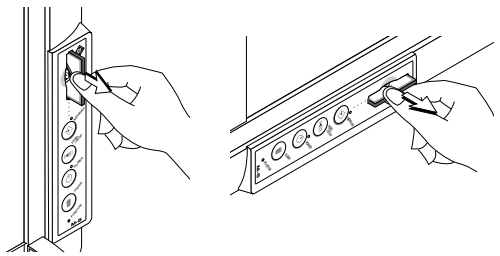

For More Info

Click Here --->



Scanning area

Effective scanning area

Scanning is not possible on the edges of sheet. Write or draw within the effective scanning area.

Notice: The effective vertical scanning area is within the ruled lines.

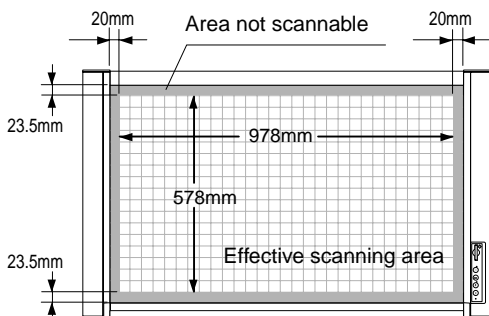

Notes on scanning the sheet surface

- When the POWER button is press to turn on the power or the MEMORY button is pressed while in the standby mode, the memory or feed operation starts after the warm-up. It is for stable sanning condition.
Under normal conditions, it takes about 20 seconds, but under certain environments, for example when the external temperature is low, some more time may be required. On this copyboard, this warm-up time is controlled by a timer and it can be changed with the setup utility.
To achieve a more stable picture quality, we recommend you to wait one minute after the fluorescent lamp turns on before storing images in the memory. The time required for operation to become stable depends on the environment.
- Note that images may not be read as well if you use markers of colors other than black and red or markers of other brands. Use the markers specified by PLUS.
- Avoid use in places exposed to abrupt changes in temperature such as near the vents of an air conditioner.
Doing so could result in the deterioration of read quality.

Operating the Copyboard

These operations are required when storing the drawings on the copyboard's sheet in the memory and when moving the sheet surface using the buttons.

Connecting the AC power adapter and turning the power on and off

The diagrams used in the explanations below show the copyboard installed in the horizontal position.

1

Connect the AC power adapter.

- 1 Connect the AC power adapter to the copyboard's DC power jack.
- 2 Connect the AC power cord to the AC power adapter.
- 3 Plug the AC power cord into a AC power outlet in a wall.

The explanations below assume this condition.

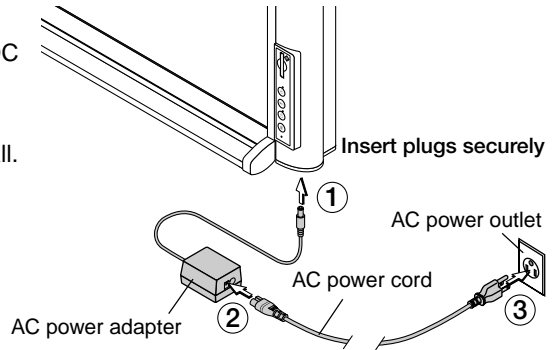

2

Press the POWER button to turn on the power.

The POWER indicator blinks for approximately 20 seconds, then stops blinking, remaining lit. The copyboard is now ready to scan images (the fluorescent lamp is lit). Drawings on the copyboard's sheet can now be stored in the memory.

Notice:

- The power mode changes to the standby if no button is operated for 30 minutes.
- When in the standby mode, the corresponding function is performed when a button is pressed.

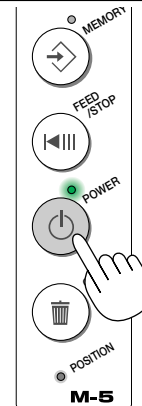

When not using the copyboard

Press the POWER button to turn the power off. The POWER indicator turns off.

Notice:

The built-in memory or CF memory card can be accessed if the USB cable is connected to a computer in this status.

Note:

- When disconnecting the AC power adapter, first unplug the power cord from the AC power outlet in the wall.
- Unplug the power cord from the wall outlet when not planning to use the copyboard for long periods of time.

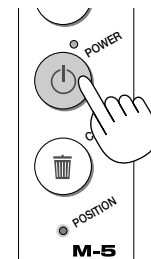

For More Info

Click Here --->

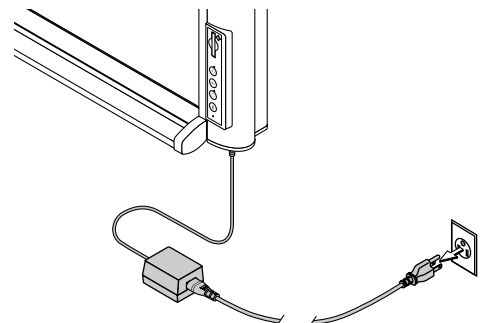

For More Info



Saving the Image on the Sheet

Click Here --->

Images drawn on the sheet can be stored either in the built-in memory or on a CF memory card. This is a black and white copyboard. Images drawn in color are stored in black and white.

■ Saving sheet images in the built-in memory

Preparations: Check that the POWER indicator is lit. If it is off, press the POWER button.

The diagrams used in the explanations below show the copyboard installed in the horizontal position.

1

Press the FEED/STOP button to move the sheet image you want to save to the front.

- There is no need to perform this operation to save the image that is currently at the front.
- When the FEED/STOP button is pressed, the sheet scrolls one page's worth to the left (or upwards) (this takes about 12 seconds), then stops automatically. To stop in the middle, press the FEED/STOP button again. (page 25)

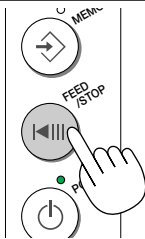

2

Press the MEMORY button to store that image in the memory.

- The sheet scrolls one page's worth to the left (or upwards), scanning starts, and the image is stored in the built-in memory.
- The MEMORY indicator blinks slowly while the image is being stored in the memory.

● If the indicator blinks intermittently

The indicator blinks intermittently (warning) when there is not enough free data space left in the built-in memory.

- * Either clear the built-in memory (see "Clearing the built-in memory" on page 25) or insert a CF memory card with enough free space on it, then press the MEMORY button again.

If the indicator starts blinking intermittently (warning) after scrolling

- * The memory may run out of space while the file is being stored. In this case, the data that was scanned is still in the memory when the indicator starts blinking intermittently.
- * To store the data in a file, insert a CF memory card with enough free space on it, then press the MEMORY button.
- * Note that the data is discarded when the memory clearing procedure is performed or when the FEED/STOP or POWER button is pressed.
- * To save the same image again, bring that sheet surface back to the front, then press the MEMORY button.

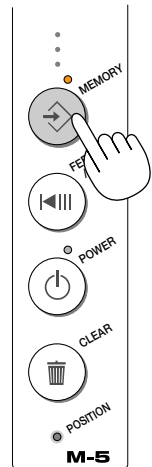

Notice:

- If a CF memory card is inserted into the card slot, the data is stored on the CF memory card, not in the built-in memory.
- The edges of the image on the sheet surface are not stored. See "Scannable area" on page 21.
- Some parts may not be read or their density built-in in the data may change (patchy letters, thin lines, portions where marker lines overlap, etc.).
- To save image files stored in the built-in memory onto a computer, see page 26.
- The maximum capacity of the built-in memory is about 1.8 MB, that is between 15 and 20 files (the amount of data per file depends on the drawings on the sheet).
- Do not press the FEED/STOP button while the image is being scanned (while the MEMORY indicator is blinking slowly). Doing so will cancel the data saving procedure and the data will be discarded.
- To move the sheet surface, press the FEED/STOP button after scrolling has stopped.
- The date of file property is fixed at January 1, 2004.
This can be changed using the "M-5 setup utility" software.

■ Saving sheet images on a CF memory card

Preparations: Check that the POWER indicator is lit. If it is off, press the POWER button.

The diagrams used in the explanations below show the copyboard installed in the horizontal position.

1 Insert the CF memory card into the copyboard's card slot.

- For instructions on inserting the CF memory card, see page 21.

For More Info

Click Here ---> 

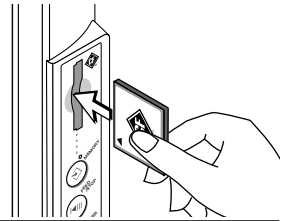

2 Press the FEED/ STOP button to move the sheet image you want to save to the front.

- There is no need to perform this operation to save the image that is currently at the front.
- When the FEED/STOP button is pressed, the sheet scrolls one page's worth to the left (or upwards) (this takes about 12 seconds), then stops automatically. To stop in the middle, press the FEED/STOP button again.

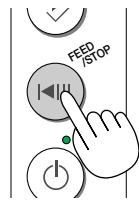

3 Press the MEMORY button to store that image in the memory.

- The sheet scrolls one page's worth to the left (or upwards), scanning starts, then the image is stored on the CF memory card.
- The MEMORY indicator blinks slowly while the image is being stored in the memory.

● If the indicator blinks intermittently

The indicator blinks intermittently (warning) when there is not enough free data space left on the CF memory card.

- * Insert a CF memory card with enough free space on it, then press the MEMORY button again.
- * To cancel the data storing procedure, press the FEED/STOP or POWER button.

If the indicator starts blinking intermittently (warning) after scrolling

- * The CF memory card may run out of space while the file is being stored. In this case, the data that was scanned is still in the memory when the indicator starts blinking intermittently.
- * To store the data in a file, insert a CF memory card with enough free space on it, then press the MEMORY button.
- * Note that the data is discarded when the FEED/STOP or POWER button is pressed.
- * To save the same image again, bring that sheet surface back to the front, then press the MEMORY button.



Notice:

- Some time may be required for some CF memory cards to be recognized.
- The edges of the image on the sheet surface are not stored. See "Scannable area" on page 21.
- Some portions may not be read or their density built-in in the data may change (patchy letters, thin lines, portions where marker lines overlap, etc.).
- Do not press the FEED/STOP button while the image is being scanned (while the MEMORY indicator is blinking slowly). Doing so will cancel the data saving procedure and the data will be discarded.
- To move the sheet surface, press the FEED/STOP button after scrolling has stopped.
- The date of file property is fixed at January 1, 2004.
This can be changed using the "M-5 setup utility" function.

4 Removing the CF memory card

Check that the MEMORY indicator has stopped blinking and turned off, then pull the CF memory card out.

Note: Do not remove the CF memory card while files are being stored (while the MEMORY indicator is blinking slowly). Doing so will damage the data. The CF memory card can be replaced while the MEMORY indicator is blinking intermittently, indicating there is not enough free memory left.

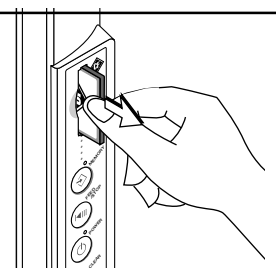

Clearing the built-in Memory

Use this procedure to clear all the image files in the built-in memory.

Note: The procedure described below clears all the image files in the built-in memory. Be sure to store important images on a CF memory card or computer before the operation.

Press the CLEAR button and hold it in for more 3 seconds.

Once the CLEAR button has been held in for more 3 seconds, the MEMORY indicator blinks slowly and file clearing starts.

When an error with the memory clearing has occurred and the indicator changes to the error blinking pattern, start over.

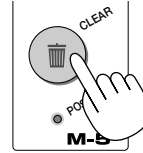

Scrolling the Sheet

Press the FEED/STOP button when you have used up the surface of the sheet and want to move to another surface to draw, or when you adjust the sheet position from which scanning is to start. The sheet can also be scrolled in the standby mode.

The diagrams used in the explanations below show the copyboard installed in the horizontal position.

■ Scrolling the sheet automatically

Press the FEED/STOP button.

The sheet scrolls one sheet's worth to the left (or upwards).

- To stop in the middle, press the FEED/STOP button again.

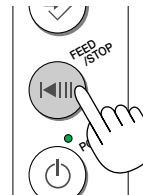

■ Scrolling the sheet manually

The sheet can be scrolled even if the copyboard's power is turned off. Move the sheet using your palm. The sheet moves either right or left (up or down *1). Place your palm at the center in the vertical (or horizontal *1) direction and move the sheet gently.

(*1 When the copyboard is installed in the vertical position.)

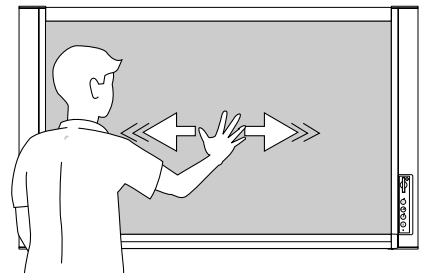

Note: Moving the sheet too abruptly may damage the copyboard's drive mechanism.

Vertical/Horizontal Position Setting

The direction in which images are stored differs according to whether the copyboard is installed in the vertical or horizontal position. (The position setting is set to horizontal upon shipment from the factory.)

1. Prepare a tool to press the button in the pin hole, for example a paper clip that has been bent out, etc.
2. Check that the POWER indicator is lit. If it is off, press the POWER button.
3. Stick the paper clip, etc., into the POSITION hole on the control panel and press.
The MEMORY indicator blinks slowly for 5 seconds, and the position setting is switched to vertical.

To switch back to horizontal, press the POSITION button again.

The POWER indicator blinks slowly for 5 seconds, and the position setting is switched back to horizontal.

The setting switches between vertical and horizontal each time the button in the pin hole is pressed.

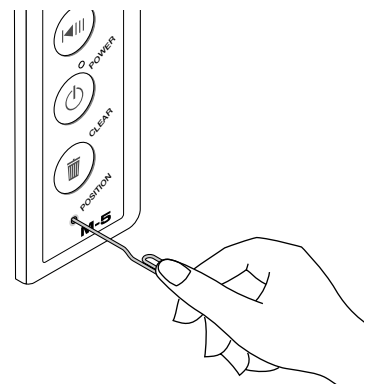

Storing Image Files on a Computer

The following describes the procedure for storing image files stored in the built-in memory or on a CF memory card onto a computer's hard disc and for erasing the files from the computer's hard disc.

- For image files stored in the built-in memory, connect the copyboard to the computer using the USB cable included in the copyboard package.
- Image files stored on a CF memory card can be stored onto the computer's hard disc using either a USB cable or a commercially available PC card adapter or CF card reader/writer.
- Computer procedures described here are for reference purposes only, and differ according to the computer's operating system. For details, refer to the computer's operating instructions or help files.
- Applicable operating systems: Microsoft Windows 98SE/Me/2000/XP
Applicable computers: Computers with full IBM PC/AT compatibility on which one of the above operating systems is installed and operating normally

Storing/Deleting Directly with USB Connections (from built-in memory or CF memory card)

Note:

- When using Windows 98SE and connecting the copyboard and computer for the first time using USB connections, be sure to install the dedicated Windows 98SE driver on the computer before connecting. (page 37)
For Windows Me, 2000 and XP, the USB driver is installed automatically. (page 39)
- The built-in memory should be used to store the copyboard information only. Do not use it as temporary storage for computer data. When a large volume of data has been written, the process can take several minutes until completion.
Formatting of the built-in memory of the copyboard from the personal computer is not possible. Also note that formatting the CF memory in the NTFS format is not supported.
- When TIFF files made with the M-5 are opened with the Image Viewer of Windows 98SE and Me, horizontal lines might appear.
In view of this, please use the supplied PLUS Image Viewer or other viewer software.
- To customers using Windows 2000
When file processing (deletion and file movement) of the built-in memory is performed with file Explorer or another utility, please wait more than 20 seconds before performing subsequent the copyboard operations or disconnecting of the USB cable. (It can take 20 seconds or longer to complete the file process in the built-in memory.)
- During memory storage with the copyboard, please do not disconnect the USB cable or access the built-in memory. Doing so could result in the operation of the personal computer becoming unstable. Please do not perform operations of the copyboard during access of the built-in memory from the personal computer. Doing so could result in excessive time being taken for the response, or operation might not be possible.

Connect the USB cable.

Use the included USB cable to connect the copyboard's USB connector to the computer's USB port.

Notice:

- Even if the POWER indicator is off, the computer automatically recognizes the copyboard when the USB cable is connected.

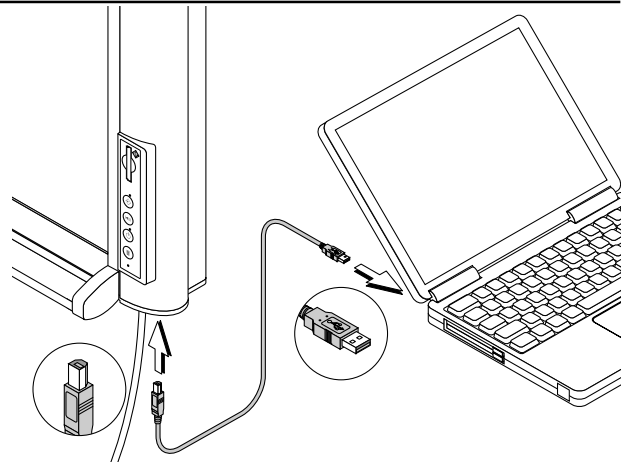

For More Info
Click Here --->



2 To store image files from a CF memory card, insert the CF memory card into the copyboard's card slot.

There is no need to do this to store image files from the built-in memory.

For More Info

Click Here --->

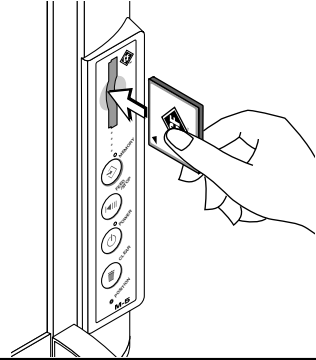

3 Open "My Computer" of the computer.

- 1 Right-click the "My Computer" icon, then left-click "Explorer" from the menu.
 - "My Computer" can also be opened by clicking on its icon.
- 2 Two additional removable memory devices appear in "My Computer".

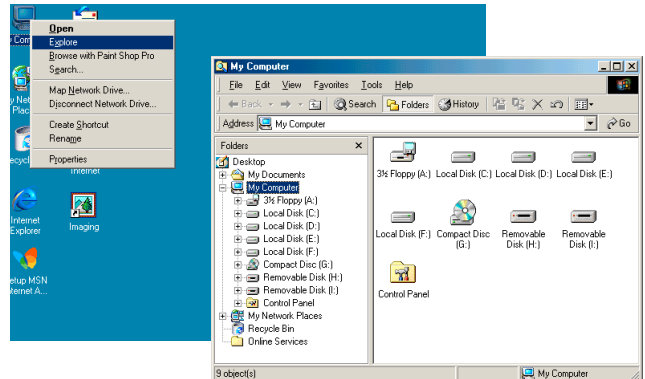

- 3 Select and open "Removable Disc [F]" (the drive character depends on the computer system). For the CF memory card, select and open "Removable Disc [G]" (the drive number depends on the computer system) from among the removable memory devices.

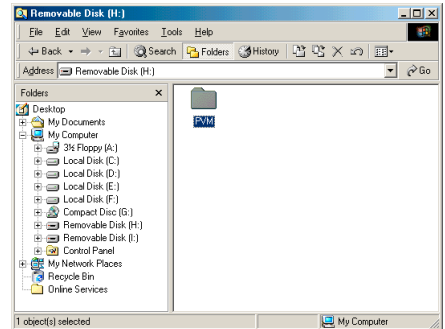

4 Store the copyboard's image folder onto the computer.

The folder name for the copyboard's image files is "PVM". Select the PVM folder, specify the destination folder to copy it at "Edit" → "Copy to folder" in Explorer, then click "OK". This is just one example of how to copy the folder.

Notice:

- The image files in the PVM folder are named "MBxxxxxx.tif", where "xxxxxx" is a 6-digit serial number assigned in the order in which the file was stored. (Ex.: MB000001.tif)
- It is also possible to use the "PLUS Image Viewer" contained in the CD-ROM to check the copyboard's image files before storing them onto or deleting them from the computer. (page 43)

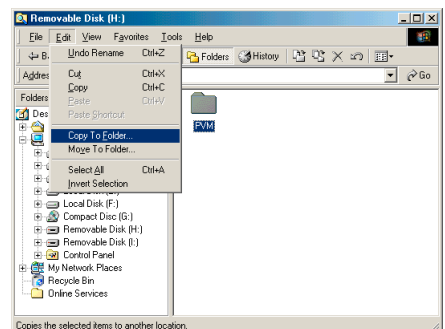

continued on next page

Deleting files

If the built-in memory or CF memory card gets full, some image files must be deleted.

(The built-in memory can be cleared completely using the CLEAR button on the copyboard's control panel.)

(1) Select the drive for the built-in memory or the CF memory card (steps 1 to 3 above).

(2) At step 3, open the PVM folder, select the image files you want to delete, then select open "File" menu in Explorer and click "Delete".

To delete all the image files at once, delete the PVM folder.

Note:

- Be sure to store (back up) important image files onto the computer or a CF memory card before clearing the built-in memory.
- Do not remove the CF memory card or disconnect the USB cable while files are being stored or deleted. Doing so will damage the data.
- These operations may not work properly if several USB devices are connected to the computer and being used simultaneously.
- If connected to a USB hub, or if connected using an extension cable these operations may not work properly. Connect directly to the computer's USB port.

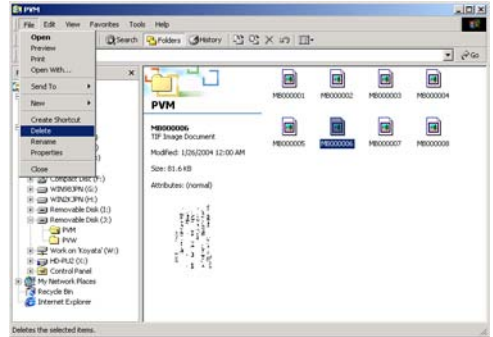

5 Disconnect the USB cable.

The disconnecting procedure depends on the computer's operating system. For details, refer to the computer's operating instructions or help files.

Windows 98SE

① Check that the MEMORY indicator has stopped blinking and turned off.

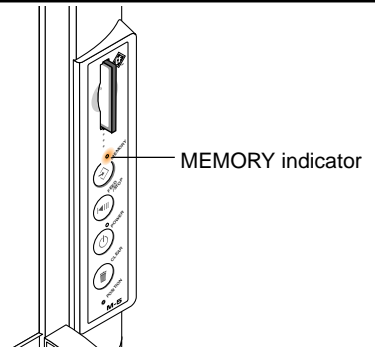

② Right click on the "Removable Disk" icon of "My Computer" and left click on "Remove" of the menu. Wait a little while before proceeding to Step ③.

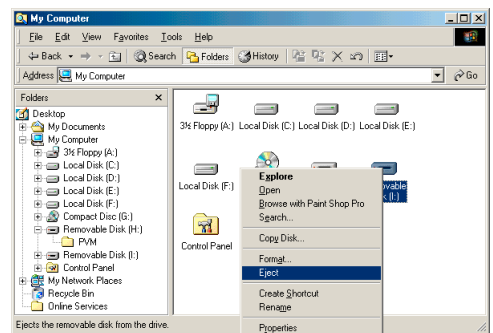

For More Info
Click Here ---->



③ Disconnect the USB cable.

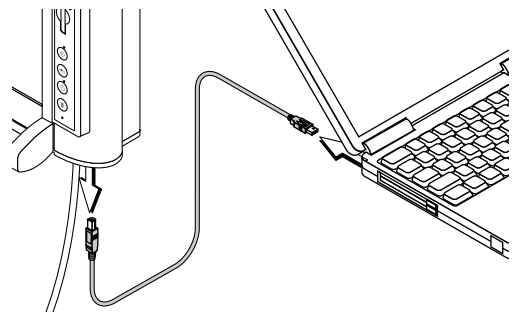

continued on next page

Windows Me/2000/XP

- ① Check that the MEMORY indicator has stopped blinking and turned off.
- ② Click the "Remove hardware" icon on the task bar, then click the USB drive you want to remove (for example, "USB Mass Storage Device (E:)").

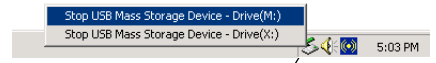

"Remove hardware" icon (example)

- ③ Once the message "The 'USB Mass storage Device' device can now safely removed from the System" appears, click "OK". (There is no "OK" button for Windows XP. Click [x] instead.)

If you were copying or deleting files stored on a CF memory card, remove the CF memory card.

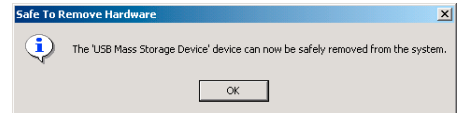

- ④ Disconnect the USB cable.

For More Info

Click Here ---->

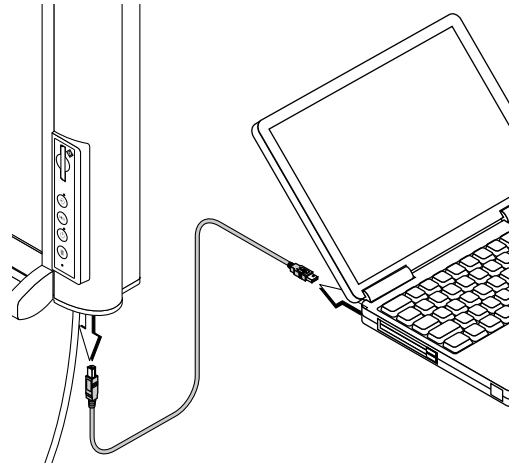

Note:

- Do not remove the CF memory card while files are being stored (while the MEMORY indicator is blinking slowly). Doing so will damage the data.
- The USB drive may not be disconnected properly, for example if the computer is in the process of checking the status of peripherals.

Using a PC Card Adapter or Memory Card Reader/Writer (USB type)

Prepare the optional or commercially available memory card reader/writer or PC card adapter (for CF memory cards).

■ Using a PC card adapter

1

Insert the CF memory card into the PC card adapter.

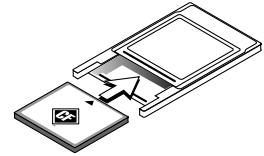

2

Insert the PC card adapter into the computer's card slot.

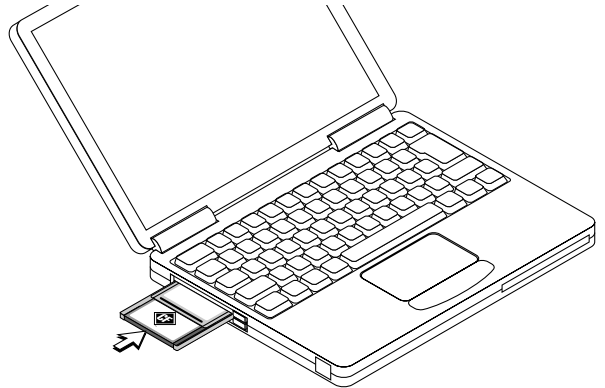

For More Info
Click Here ---->



3

Open "My Computer" of the computer.

"My Computer" can also be opened by clicking on its icon. From among the removable memory devices shown in "My Computer", select and open "Removable Disc [F]" (the drive character ("F" in this example) depends on the computer system).

For subsequent operations, please see steps 4 and on under "Storing/Deleting Directly with USB Connections" on page 27.

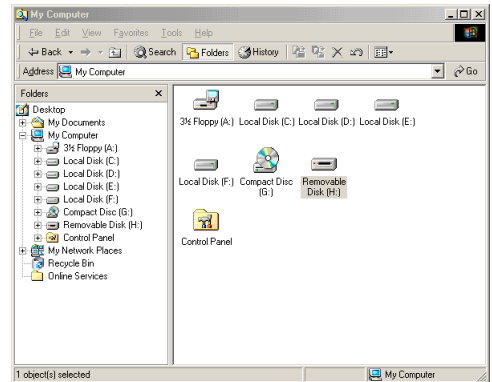

- To remove the PC card adapter, click the "Remove hardware" icon on the task bar, then select the controller driver (for example, "PCM-CIA IDE/ATAPI controller drive (E:)").



■ Using a memory card reader/writer (USB type)

1 Insert the CF memory card into the CF memory card slot on the memory card reader/writer.

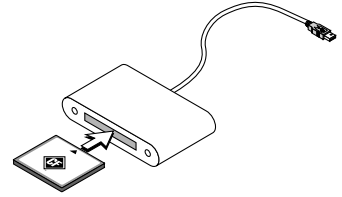

2 Connect the memory card reader/writer to the computer's USB port.

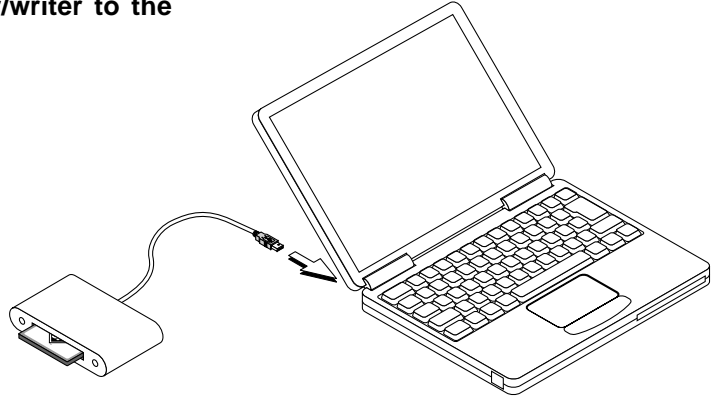

3 Open "My Computer" of the computer.

"My Computer" can also be opened by clicking on its icon. From among the removable memory devices shown in "My Computer", select the drive corresponding to the CF memory card.

The drive character depends on the computer system and the number of slots in the memory card reader/writer. If you do not know, search for the removable drive on which the PVM folder is stored.

For subsequent operations, please see steps 4 and on under "Storing/Deleting Directly with USB Connections" on page 27.

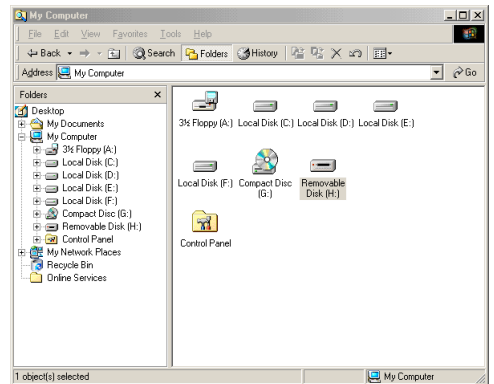

For More Info 
Click Here --->

Troubleshooting

Check the following before asking for repairs.

Symptom	Check
Power does not turn on when POWER button pressed	<ul style="list-style-type: none"> Check that the AC power adapter's cord is connected to the DC input jack and to a wall outlet.
Writing on the sheet does not erase with the eraser.	<ul style="list-style-type: none"> Are you using a marker other than one specifically designated for use with this copyboard? (Apply some water or neutral detergent to a soft cloth, wring out thoroughly, then wipe the sheet carefully and gently.)
Some letters or lines are not read.	<ul style="list-style-type: none"> It may not be possible to read letters or lines if the letters are patchy or the lines are thin. Depending on the operating environment, the picture quality may not be stable directly after the fluorescent lamp is lit. Wait about 5 minutes after turning on the fluorescent lamp then try to store the image data again. Adjust the density using the M-5 setup utility. Try performing the quick calibration. (See Page 34.)
Scanned images are dirty	<ul style="list-style-type: none"> Is there a lot of marker residue on the sheet? (If the sheet is dirty, apply some water or neutral detergent to a soft cloth, wring out thoroughly, then wipe the sheet carefully but gently.) Try performing the quick calibration. (See Page 34.)
There are black bands at the top and bottom of scanned images	<ul style="list-style-type: none"> The fluorescent lamp may be at the end of its service life. Contact your store of purchase or a PLUS customer center to have the lamp replaced. Perform the quick calibration procedure. (See Page 34.)
Ruled lines are scanned along with image	<ul style="list-style-type: none"> Adjust the brightness using the M-5 setup utility. Try performing the quick calibration. (See Page 34.)
Scanned images are inverted horizontally and vertically	<ul style="list-style-type: none"> Is the vertical/horizontal position setting correct? Change the setting as described under "Vertical/Horizontal Position Setting" on page 25.
The Memory indicator and the Power indicator blink alternately at a high rate.	<ul style="list-style-type: none"> This could indicate a problem with the fluorescent lamp inside, a calibration error or an error with the internal memory (data cannot be stored or deleted). Contact your nearby PLUS Vision sales office, dealer, or store.
The Memory indicator and the Power indicator blink alternately at a high rate and return to their original condition after several seconds.	<ul style="list-style-type: none"> <ul style="list-style-type: none"> CF memory card-related error <ul style="list-style-type: none"> CF memory storing error Use a CF memory card (or adapter) that has been checked for proper operation by PLUS. More information is available on the PLUS web site. (http://www.plus-vision.com) Error in changing the vertical/horizontal position setting Try pressing the POSITION button again.
MEMORY indicator blinks intermittently	<ul style="list-style-type: none"> There is not enough free data space left in the built-in memory or on the CF memory card. Make some free space, then store the data. (See "If the MEMORY indicator blinks intermittently" on pages 23 and 24.)

* If an error occurs, it is stored in the built-in memory's error log. The error log file ("M5.err") may be needed if the error cannot be resolved. Please save this file.

* If the problem persists after all the above has been checked, contact your nearby PLUS Vision sales office, dealer, or store.

For More Info

Click Here ---->



Specifications

Type	Method of installation	Mounted on wall (horizontal position) Options : stand mount (horizontal/vertical position), partition-wall mount (horizontal mount)
	External dimensions (main unit only)	W1175 × H708 × D93 mm (not including projecting parts)
	Weight (main unit)	12.5 kg
Board	Board surface dimensions	W1018 × H625 mm
	Effective scanning area	W978 × H578 mm
	No. sheet surfaces	2
	Page feeding	Motorized (Forward) & Manual (Forward & Reverse)
	Drive method	Sheet transport type (left scroll when installed horizontally, upwards scroll when installed vertically)
	Scanning method	Black & white CCD sensor
	Scanning resolution	2.7 dots/mm (equivalent of 66 dpi)
	Scanning time	Approx. 12 sec.
	Scanning light source	Cold Cathode Fluorescent Lamp (CCFL)
Memory	Built-in memory	Flash memory, Data capacity: Approx. 1.8 MB
	External memory	CompactFlash (CF) memory card type I and type II *1
	Compatible FAT types	FAT 12, 16 and 32
	File format	TIFF format (PackBits compression) (PNG format available as option)
Control panel	Control buttons	Power, memory, clear, feed/stop and position
	Indicators	Power LED (green), Memory LED (orange)
Computer connection	Interface	USB 2.0 compliant Full Speed 12 Mbps
	Connecter	USB B type
	Compatible computers	Computers with a USB port on which Windows 98SE, Me, 2000 or XP is installed
	Driver software	Windows 98SE driver is supplied. (Standard operating system driver for Windows Me, 2000 and XP)
Power supply	AC power adapter	Input : AC100 – 240V, 50 – 60 Hz
		Output : DC 19V, 3.42A
		Power consumption : Approx. 40 W
Environmental Conditions	Temperatures	50°F–95°F (10°C to 35°C)
	Humidity	30% to 85% without condensation
Others	Ruled lines	34 mm cross-ruled squares
Accessories	Markers (red and black), Eraser, AC power adapter (3 meter power cord), USB cable (3 meters), Software CD-ROM, User's Manual (simplified Edition), Wall mount positioning sheet, Wall mount fittings.	

*1 CF memory cards sold separately.

* Please note that for quality improvement purposes, specifications and design are subject to change without prior notice.

For More Info 
 Click Here --->

Quick Calibration

The procedure described below is used to adjust (calibrate) for optimum scanning condition of the sheet surface. Perform this quick calibration procedure after replacing the fluorescent lamp or if dark lines appear in the horizontal direction when the copyboard is mounted on the wall.

1 Clean the sheet surface.

First clean a strip about 10 cm wide along the left side of the sheet surface.

Make sure the sheet is completely clean and there are no marker traces left.

- * Apply some water to a soft cloth, wring out thoroughly, then wipe the sheet clean. For tough dirt, wipe using a clean cloth with a solution of diluted neutral detergent, then wipe again with a cloth dampened with water to remove all traces of the detergent.

Caution:

Move the sheet so that the seam of the sheet does not enter the 10 cm portion at the left side which is going to be cleaned.

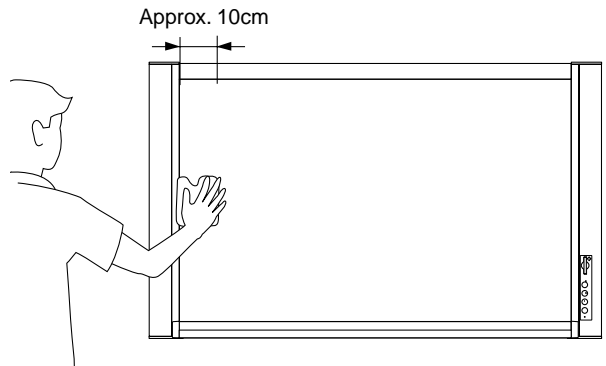

2

Start the calibration procedure.

Preparations: If the power cord is plugged into a power outlet, unplug it.

Plug the power cord into a power outlet while pressing the FEED/STOP button.

- The sheet automatically moves about one brock of ruled line and calibration is performed.
- The MEMORY indicator blinks slowly during this process (calibration takes about 5 minutes).
- The power turns off once calibration is completed. All copyboard operations can be made after turning on the power.

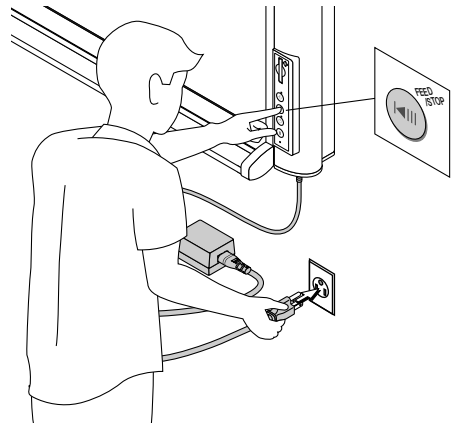

For More Info

Click Here --->



Software Guide



This guide covers the installation and starting procedure for the software contained on the CD-ROM supplied with the Copyboard.

See the software Help information for details about using the software.

For More Info

Click Here --->



Before Using the Software

Software Contents and Overview

The supplied CD-ROM contains the software and manuals described below. See the Help information of the various software programs for information about how to use the software.

■ M-5 USB Driver (Windows 98SE)

This driver software makes the computer recognizes the Copyboard as an external device when there is a USB connection. This driver is for use with Windows 98SE only. No driver is required if the computer has Windows ME/2000/XP.

■ M-5 Setup Utility

This is a utility for customizing the M-5's environmental settings.

■ PLUS Image Viewer

This utility is used to display on a personal computer or print the image data that is stored in the built-in memory or the CF memory.

■ M-5 User's Manual

The User's Manual is stored on the CD-ROM in PDF format.

■ Acrobat Reader

This software is used to view PDF type files.

● Browsing the CD-ROM

Explorer running on the personal computer is used to display the contents of the CD-ROM.

● Copyrights and usage conditions

This opens the copyrights, usage conditions, etc.

Note: When installing on Windows 2000, please install the software with "Administrator" authority (i.e., a user having administrator authority).

When installing on Windows XP, please install the software with "Computer Administrator" authority (account).

Notice: Format for HELP

The help of the PLUS Image Viewer uses the online help system that is used for Microsoft HTML Help.



[Start menu]

Operating Environment

Supported OS:	Microsoft Windows 98SE / Me / 2000 Professional (Service Pack 3 or later) / XP (Home Edition / Professional Edition Service Pack 1 or later)
Supported PC:	IBM PC/AT or completely compatible machines that operate the aforementioned OS
CPU:	Pentium II or later
Memory:	Windows 98SE / Me (64 MB or bigger), Windows 2000 (128 MB or bigger), Windows XP (256 MB or bigger)
Free hard disk space:	40 MB or bigger
Display resolution:	800 × 600 pixels or higher
Peripheral devices:	a CD-ROM drive, a standard USB port (USB 1.1 or 2.0)
Web browser:	Internet Explorer 5.0 or later

Note: • All operations are not guaranteed under the aforementioned operating environment.
• Not compatible with Windows 95, NT, 2000 Server or Server 2003.

For More Info



Windows 98SE Personal Computer and USB Connections

To make a USB connection with the Copyboard and a personal computer with Windows 98SE, please set up the driver according to the following procedure.

Driver Setup (Windows 98SE)

Note:

- **Do not connect the Copyboard with the personal computer until Step 4.**
- When using Windows Me, 2000, or XP, driver setup is not required. Make a USB connection with the Copyboard. The Windows standard driver will be installed automatically.
- This driver does not support Windows 95 or NT, 2000 Server or Server 2003.

Setup flow



1 Installation preparation

Please close application software that is running on the personal computer. Failure to close the applications may result in installation problems.

2 Load the supplied CD-ROM into the CD-ROM drive of the personal computer.

The menu screen will appear automatically.

- If the menu screen does not appear automatically, open the CD-ROM and double click on "autorun.exe".



3 Click the [M-5 USB Driver]

The installer will start up. Follow the messages of the screen and perform the installation.

Note: When the copyboard is connected before setup, a screen requesting the driver will appear. Click "Cancel" and disconnect the power cable of the unit.

Under these circumstances, restart the personal computer following driver setup.

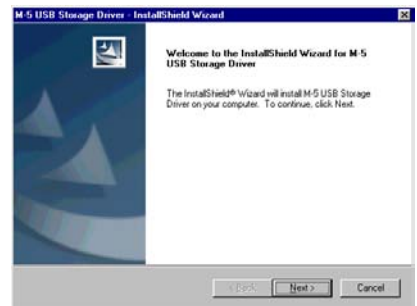

4 Making connections with the Copyboard

Connect the USB connector of the Copyboard with that of the personal computer using a USB cable, then plug the power cable into the power outlet.

- When connection is first made with the Copyboard, the "New hardware addition wizard" screen will appear. Please follow the instructions on the screen.
- Please check that the Copyboard is operating properly.

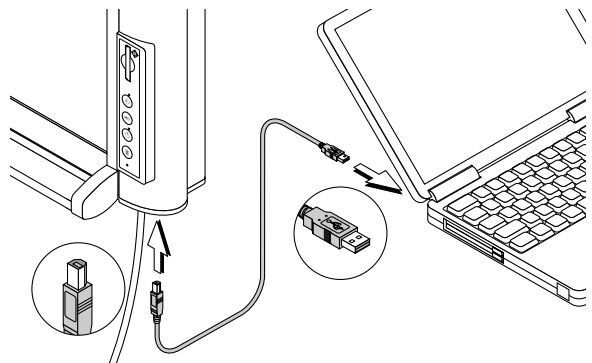

For More Info

Click Here --->



5 Open the Device Manager screen and check the installation.

- 1 Right click [My Computer], then click on [Properties] of the menu to open the [System Properties] screen.
- 2 Click the tab of the Device Manager to switch to the [Device Manager] screen.
- 3 Click [+] located to the left of [Disk drives] and check that the driver name described at the right is displayed.

This completes the setup.

Note: When [!] or [x] is appended, please delete the driver and then perform setup again. To delete, right click above the drive having the [!] or [x] mark to display the menu, then click [Remove] to perform the deletion.

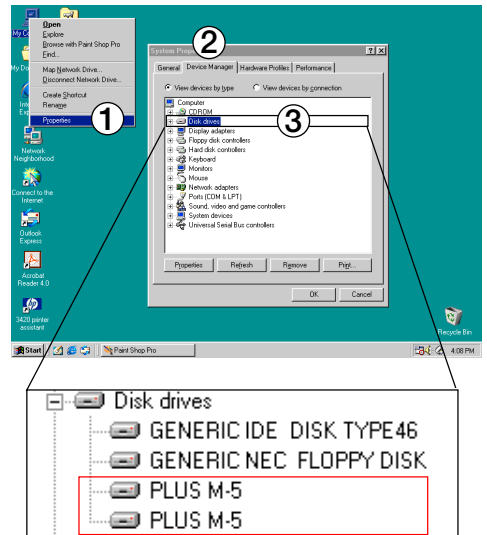

Uninstalling the Driver (Windows 98SE)

To uninstall the driver, follow the procedure described below.

1 Open the Software Addition and Deletion screen.

- 1 Clicking on [Setting] → [Control Panel] of the [Start] menu will open the Control Panel screen.
- 2 Clicking on the [Add/Remove Programs] icon will open the Software Addition and Deletion screen.



2 Uninstall the M-5 driver.

- 1 Click [M-5 USB Storage Driver] and click [Addition and Deletion] to display the Addition and Deletion wizard screen.
- 2 Select the [Remove] button of the wizard and click [Next]. The uninstallation process will begin.



For More Info

Click Here --->



Windows Me / 2000/ XP Personal Computer and USB Connections

Setup of the driver is not required when USB connections are made between Windows Me / 2000 / XP personal computers and the Copyboard. When the Copyboard is first connected to the personal computer, the driver is installed automatically.

1 Connect the Copyboard with the personal computer.

Connect the USB connector of the Copyboard with that of the personal computer using a USB cable and then press the POWER button of the Copyboard to switch on the power.

Windows standard driver will be installed automatically.

Note: For Windows ME, the operating system's CD-ROM or floppy disk may be requested.

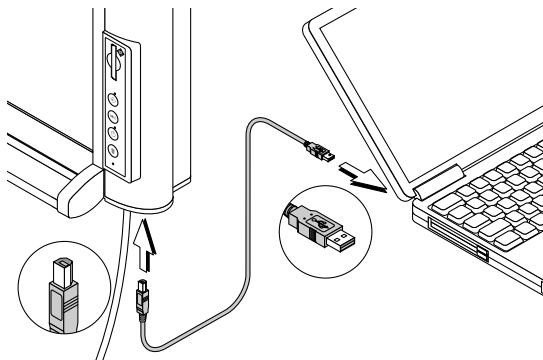

2 Check whether the Copyboard is operating properly.

- ① Right click [My Computer], then click on [Properties] of the menu to open the [System Properties] screen.
 - When using Windows XP, right click [My Computer] on the [Start] menu and click [Management].
- ② Click the tab of the Device Manager to switch to the [Device Manager] screen.
- ③ Click [+] located to the left of [Disc Drive] and check that the driver name described at the right is displayed.

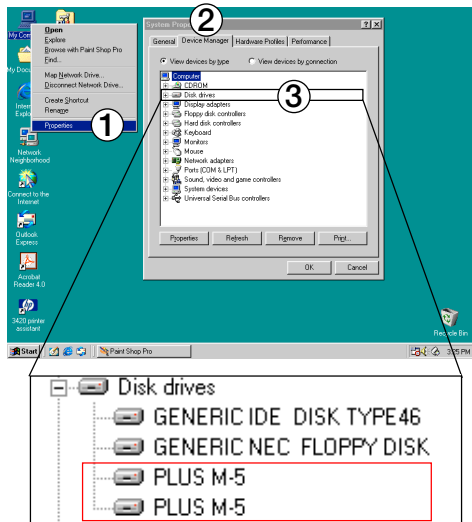

For More Info
Click Here --->



Disconnecting of the Copyboard

Please perform the following procedure when disconnecting the Copyboard during Windows operation.

Note: The removal icon or displayed message will differ depending on the version of Windows. Should this be the case, please perform the removal operation using the same procedure.

Windows 98SE



The personal computer will be disconnected.

- ① Check that the blinking of the Memory indicator has changed to the indicator being off.
- ② Right click on the "Removable Disk" icon of "My Computer" and left click on "Eject" of the menu. Wait a little while before proceeding to Step).



2 Disconnect the USB cable from the personal computer.

For More Info

Click Here ---->



Windows Me / 2000 / XP



Perform the disconnection of the personal computer.

- ① Click the [Hardware Removal] icon (Example: ) that is displayed in the task tray.
- ② Click "Stop USB Mass storage Device - drive (E)". (The E drive character will differ depending on the personal computer system.)
- ③ Click [OK] when "The 'USB Mass storage Device' device can now safely removed from the System" is displayed.
 - When using Windows XP, [OK] does not appear on the message screen. Simply disconnect.

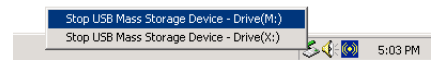

"Remove hardware" icon (example)

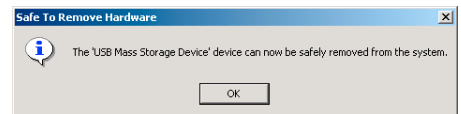

Disconnect the USB cable from the personal computer.

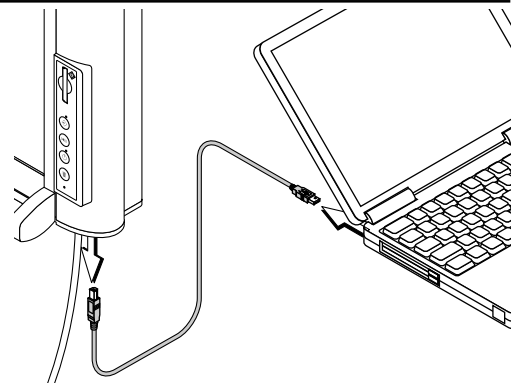

M-5 Setup Utility

The M-5's operating configuration can be changed using the M-5 setup utility.

Contents: Image file format, image file time stamp, auto power off time, fluorescent lamp warming up time, brightness adjustment, vertical/horizontal setting, secure clear

Installation

1 Installation preparation

Please close application software that is running on the personal computer. Failure to close the applications may result in installation problems.

2 Load the supplied CD-ROM into the CD-ROM drive of the personal computer.

The menu screen will appear automatically.

If the menu screen does not appear automatically, open the CD-ROM and double click on "autorun.exe".

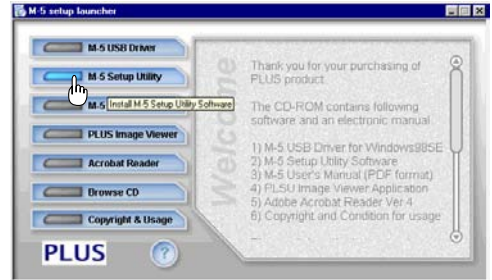

3 Click [M-5 Setup Utility].

The installer will start. Perform the installation according to the screen messages.

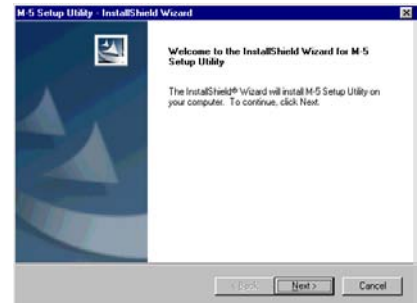

For More Info

Click Here --->



Starting up

On the personal computer click [Start] → [Program] → [PLUS Copyboard] → [M-5 Setup Utility].

The M-5 Setup Utility will start.

See [M-5 Setup Utility Help] for information about use.

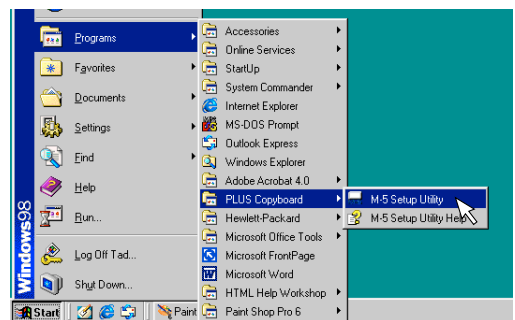

Electronic User's Manual

The User's Manual stored on the CD-ROM is in the PDF format. [Acrobat Reader] should first be installed if not already installed in the personal computer environment.

Acrobat Reader Installation

1 Installation preparation

Please close application software that is running on the personal computer. Failure to close the applications may result in installation problems.

2 Load the supplied CD-ROM into the CD-ROM drive of the personal computer.

The menu screen will appear automatically.

- If the menu screen does not appear automatically, open the CD-ROM and double click on "autorun.exe".



3 Click [Acrobat Reader].

The installer will start. Perform the installation according to the screen messages.

On the installation completion screen, enter a check at [Yes, restart my computer], then click [Finish].

For More Info

Click Here --->



Opening the M-5 User's Manual

1 Load the supplied CD-ROM into the CD-ROM drive of the personal computer.

The menu screen will appear automatically.

- If the menu screen does not appear automatically, open the CD-ROM and double click on "autorun.exe".

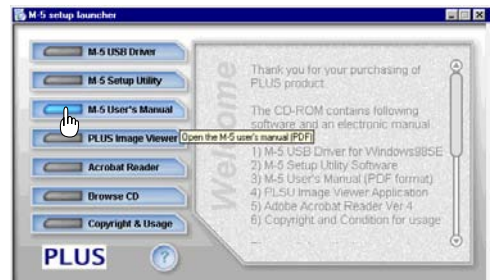

2 A click of [M-5 User's Manual] will open the User's Manual.

PLUS Image Viewer

Please install the PLUS Image Viewer to display on a personal computer, print or file the image data that is stored in the built-in memory or the CF memory.

Installation

1 Installation preparation

Please close application software that is running on the personal computer. Failure to close the applications may result in installation problems.

2 Load the supplied CD-ROM into the CD-ROM drive of the personal computer.

The menu screen will appear automatically.

If the menu screen does not appear automatically, open the CD-ROM and double click on "autorun.exe".

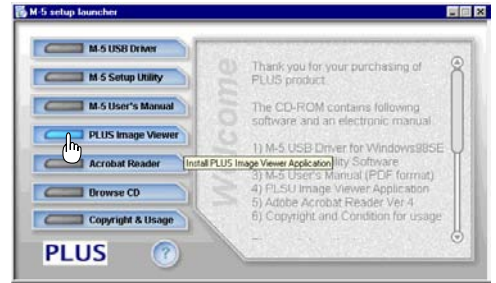

3 Click [Image Viewer].

The installer will start. Perform the installation according to the screen messages.

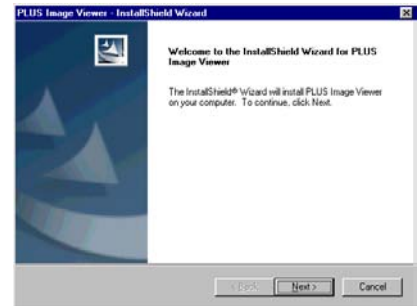

For More Info



Click Here --->

Starting up

On the personal computer click [Start] → [Program] → [PLUS Copyboard] → [PLUS Image Viewer].

The PLUS Image Viewer will start.

See [PLUS Image Viewer Help] for information about use.

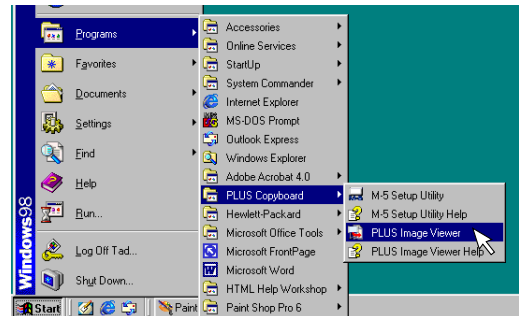

Deleting the Software

If the installed software is no longer needed, please perform the uninstall operation.

1 Select [Start] → [Setting]→ [Control Panel].
The Control Panel screen will be displayed.

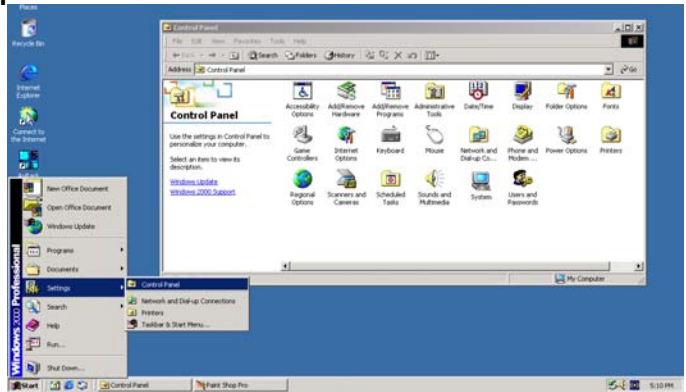

2 Double click "Add/Remove Programs or Applications" (which will differ depending on the OS).
The "Add/Remove Properties" screen will be displayed. Select the program that is to be deleted from among the list display, then click [Change/Remove].

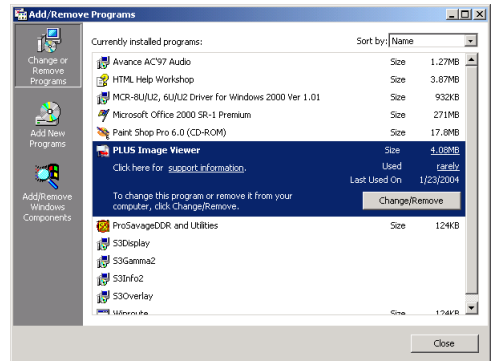

3 Select the [Remove] button of the wizard and click [Next].
The uninstallation process will begin.

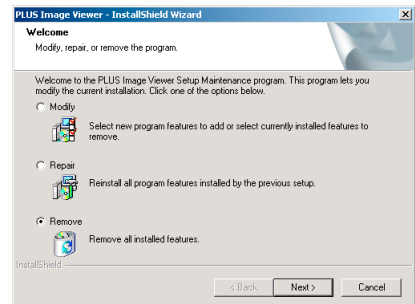

For More Info

Click Here --->



For More Info
Click Here ---> 

PLUS Vision Corp.

20-11, Otowa 1-chome, Bunkyo-ku, Tokyo, 112-0013 JAPAN

www.plus-vision.com

email:plusvision@plus.co.jp



Iruma Factory of PLUS Vision Corp. has
ISO 9001 certification.
Certificate No. 12 100 17398 TMS



Iruma Office/Iruma Factory of PLUS Vision Corp. has
ISO 14001 certification.
Certificate No. NQE-0210118A